



Petroleum Power Program Tractor Project

Unit 2

Assuring Safe & Efficient Tractor Operation



Welcome to the second unit in the 4-H tractor project series. This year my twin sister Carla and our farm friends join me in guiding you through this manual to help ensure safe tractor operation and maintenance.

Unit one helped you get acquainted with the tractor. You studied the history of the tractor; safety practices; basic information about tractor systems; and minor maintenance and service. You also should have become familiar with the operator's manual, instrument panel and controls, and starting and stopping the tractor in preparing yourself to drive. The underlying theme was *safety*. The next step, in this unit, is *operation, care and maintenance*.

We challenge you to more in-depth study of tractor systems, fuels and lubricants, servicing the tractor, keeping operating cost records, and learning more about tractor operation and maintenance, including universal hand signals for communicating with tractor drivers.

As always, "Learning-by-Doing" is the key to 4-H success. So remember to complete the suggested activities and answer the quiz questions supplied at the end of each lesson. Both will help round out your knowledge and skills in tractor safety, operation and care.



Wishing You Good Luck!

Careful Carl & Carla and Friends

Acknowledgements

This educational material has been prepared in consultation with the National 4-H Tractor Task Force comprised of representatives of Extension Service, United States Department of Agriculture, the Cooperative Extension Service of the State Land-Grant Universities and National 4-H Council.

Special thanks are extended to Amoco Foundation, Inc., donor for the National 4-H Petroleum Power Awards program, for financial assistance. Special thanks are also extended to Deere & Company for use of the technical illustrations used throughout this publication. Illustrations shown are from the following Deere publications:

FMO Agricultural Machinery Safety
FMO Preventive Maintenance
FOS Electrical Systems
FOS Engines
FOS Hydraulics
FOS Power Trains



This material is published by National 4-H Council, 7100 Connecticut Avenue, Chevy Chase, Maryland, 20815. National 4-H Council is a not-for-profit educational organization that utilizes private resources to help expand and strengthen the 4-H program. 4-H is the youth education program of the Cooperative Extension Service of the State Land-Grant Universities and the U.S. Department of Agriculture.

Programs and educational materials supported by National 4-H Council are available to all persons regardless of race, color, sex, age, religion, national origin or disability. Council is an equal opportunity employer.

©1986

Contents

I.	Safe Tractor Operation	3
	The Tractor, Safety and You	3
	Thinking and Acting Safely	3
	Begin With Safe Equipment	3
	Safety Practices to Know and Use	3
	Universal Hand Signals	5
II.	Record Keeping	8
	Servicing Forms	8
	Recording Fuel, Oil and Repairs	9
	Operating Costs	9
III.	Fuels and Lubricants	10
	Fuels	10
	Engine Oils	10
	Lubricants	11
IV.	Fuel Systems	13
	Diesel Fuel System	13
	Spark-Ignition Engines	14
	Engine Air Supply and Cleaners (Filters)	15
V.	Lubricating the Tractor	18
	Engine Lubrication	18
	Oil Filters and Systems	18
	Servicing the Lubrication System	19
	Greasing the Tractor	19
	Lubricating Other Systems	20
VI.	Electrical System	22
	The Battery	22
	Starting Circuit	23
	Charging Circuit	23
	Ignition Circuit	24
VII.	Cooling System	27
	Water-Cooled Systems	27
	Air-Cooled Systems	29
VIII.	Hydraulic System	31
	The Hydraulic Principle	31
	Hydraulic System Maintenance	32
IX.	Drive Train	34
	The Clutch	34
	Transmissions	35
	Differentials	36
	Final Drives	36
	Maintenance	37
X.	Glossary	39

SAFE TRACTOR OPERATION

The Tractor, Safety & You

You have learned several reasons why it is important to maintain a tractor properly. Good tractor care results in longer tractor life, more power and lower operating costs. If you learn how to do small but important maintenance jobs yourself, you will get better production from your tractor while helping to reduce the need for major repairs and high maintenance costs.

While learning to care for your tractor, you should also be learning safe operating procedures. 'Thinking' safety and 'acting' safely around the farm can help save lives.

Thinking and Acting Safely

*"I was in a hurry." . . . "I got careless" . . .
"I thought I could get out of the way in
time."*

How many times have you heard these excuses from persons who have had accidents? Why? Because we become hurried, careless, preoccupied and try to do more in a given amount of time than can be done safely. When we get behind in our work we take too many chances. That results in accidents!

Did you know that the tractor is involved in more accidents than any other farm machine? One source reports that when an accident occurs due to human error it is usually because someone failed to obey a safety precaution and made one or more of these mistakes:

1. Forgot an operating function—such as not setting the brake or not placing the gearshift into "park" position before dismounting.
2. Took a shortcut—such as trying to operate tractor controls from the ground.
3. Took a safety risk—such as stepping over a rotating power take-off (PTO) shaft or refueling while smoking.
4. Ignored a warning—such as "Disengage power and shut off engine before adjusting or lubricating the machine."
5. Failing to recognize a hazard.

As a member of the 4-H tractor program you should make a commitment to helping reduce

tractor accidents. You can become a safe tractor operator by forming two important safety habits: (1) Be sure the equipment you operate is safe, and (2) Keep a proper attitude — one that lets you think safety and act safely so you can avoid hazardous or accidental situations.

Begin with Safe Equipment

Every time you get ready to start your tractor make sure it is mechanically safe to operate. That goes for all other machines, too. You can give your tractor a complete daily maintenance and safety check in less than five minutes. Use a method that lets you start at one place on the tractor and move completely around it. Include the seat, steering, breaks, clutch, platform, wheels, tires, hitch and PTO in your check. You can add other items as necessary.

Seats on tractors have several adjustments. Adjust the seat to your size and weight. You need to be able to reach and operate all controls from a comfortable sitting position. Check all the bolts and screws. If any are loose or missing make repairs immediately.

Good brakes are important, too. Brakes wear with use. For this reason they must be checked regularly. Form the habit of stopping your tractor by slowing down the engine. Don't jam on the brakes to make a stop unless it is necessary to avoid an accident!

Safety Practices to Know and Use

Safe handling and storing of fuels: If not handled properly, petroleum products can cause fires and explosions. The explosive force of one gallon of gasoline, vaporized and mixed with air, is equal to 87 pounds of dynamite.

Where underground storage is not feasible, safe fuel storage may be provided by a good aboveground tank. Locate it as far as practical from buildings. (Forty feet is considered a minimum.) A shutoff valve between the hose and the tank is a must. The valve should be one that will stop the flow of fuel in case of fire.

Never refuel a tractor while it is running or even while the engine is hot. It's the fuel vapor which burns, and a hot manifold or spark could

ignite it. If fuel spills, always let it evaporate before starting the engine.

Never allow smoking or an open flame near fuel storage areas.

Fire Extinguishers. Do you have a fire extinguisher on your tractor? Do you have one in the shed where the tractor is stored? You need to have fire extinguishers in these areas and know how to use them. Use only extinguishers that are approved for use on petroleum fires. Carbon dioxide (CO₂) and dry chemical extinguishers are approved extinguishers. (See Fig. 1-1.)



Figure 1-1
KEEP A FIRE EXTINGUISHER ON HAND IN THE TRACTOR SHED. MAKE SURE IT IS APPROVED FOR USE ON PETROLEUM FIRES.

Radiators. If the radiator has a pressure cooling system let it cool before removing the radiator cap. The water in this system quickly turns to steam when the cap is removed and the pressure is suddenly released. When removing the radiator cap, first place several layers of cloth over the cap as a precaution against being burned by the steam. Then turn the cap slowly, letting out a little steam at a time, and remove.

Exhaust gases contain carbon monoxide (CO), a deadly poison. It can kill! You can't smell it or see it so you have no way of knowing when a deadly amount is present. Always run an engine out of doors so the fumes can escape. If you must run an engine inside, keep the doors open for good ventilation.

Tractor Overturns

Five out of ten tractor-related deaths occur when the machine rolls over on someone. There are many ways a tractor can overturn. Let's look at three common causes.

A tractor can tip over sideways if a wheel drops into a hole or hits an obstruction. It can also tip over when making turns. The greater the speed the more likely the tractor will tip over. Slow down. Be careful to avoid obstructions or holes and be careful when making turns.

When working in hilly or sloping fields be cautious of sideways or backward upset. Have the rear wheels adjusted to a wide position when

working along a slope to help protect from a sideways upset. Also, be very careful when driving or pulling a load up a hill. The chance of a tractor upsetting backward increases when the front end is higher than the back end. Let the clutch out very slowly when starting up a slope. Keep the hitch point at standard level, which is 13-21 inches above the ground depending on tractor size. Pulling a heavy load with the drawbar too high will cause a tractor to upset backward.

Tractors can even upset in level areas. Be especially careful when working along deep ditches or streams. Keep the tractor back from the edge for a distance at least equal to the depth of the ditch.

Tractor Run Overs

Two out of every ten persons (20%) killed by tractors are run over. About half are run over after falling from their tractors.

Some important rules to remember:

1. The operator should be the only person on the tractor any time it is in motion.
2. Operate the tractor only when in the tractor seat.
3. Fasten your safety belt if your tractor is equipped with a roll-over protection device, but don't use the belt if your tractor has no such device.
4. Be sure you know where all helpers or bystanders are at all times. Make sure they are not in the tractor's path.

Following these rules will help protect you and others from run-over situations.

Power Take-Off Devices

Even though the PTO shaft is almost always well marked as a danger point, one out of ten deaths from tractor operation occur at the power take-off. An unguarded shaft is dangerous at any speed. It can quickly catch loose clothing, twine, rope or chains you might be wearing or holding. Once caught, you are helpless against the power of your tractor.

Never operate a tractor unless the power take-off is covered with a shield (Fig. 1-2). One type of shield covers the top and sides of the shaft. Another is fastened to the PTO. It will rotate slowly when the PTO is in use but will stop if it is touched. You can't always tell whether a PTO shaft is guarded by a loose shield while operating. To be safe, treat it as an unguarded shaft and stay away from it.

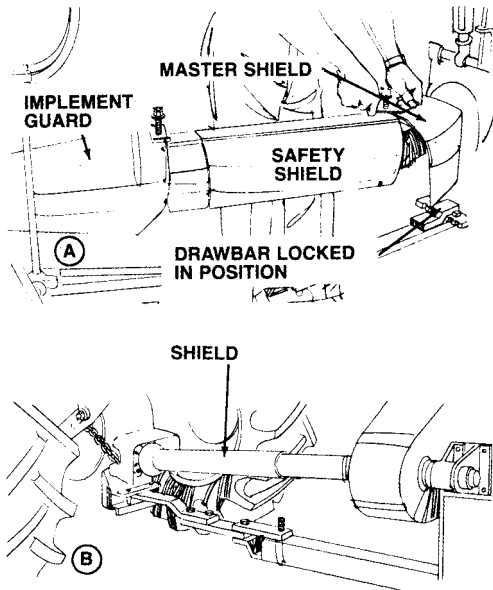

Figure 1-2
SHIELDS MUST BE USED TO PROTECT PERSONS FROM ROTATING PTO SHAFTS.

The PTO stub should be protected when it is not in use (Fig. 1-3). This can be done with a stub shield. Some tractors also have front PTO shafts. These should be shielded for protection the same as a rear PTO.

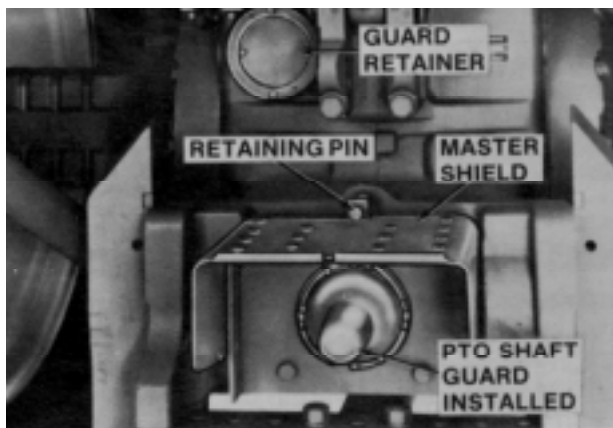

Figure 1-3
A SHIELD AND GUARD SHOULD COVER THE PTO SHAFT STUB.

Universal Hand Signals

You probably know what it's like to try to talk to your mom or dad when the water's running or when household appliances are in use. It is difficult to hear for the noise. Well, the same principle applies when the tractor is in use. When the noise level is high you can't always hear what another person is saying, so hand signals have been developed to assist in giving directions while working in the field.

There's a universal set of hand signals that you and others should learn. These are helpful in noisy surroundings or when working at some distance from another person. Take time to learn them. You can start at home in front of the mirror. Graduate to in-person drills with a friend. Practice them in the field at every opportunity. Figure 1-4 shows how Careful Carl and Carla practice in front of the mirror.

Learn by Doing

1. Check to make sure all protective devices (PTO shields, canopies, seat belts, etc.) are available and in working order on a tractor. You should also check over implements, such as power lawnmowers and garden tractors, to determine whether required protective shields and guards are in place.

Find recent statistics on tractor-related deaths and accidents in your state or the United States. (National Safety Council publications in the library or local Extension agents are good sources.) What are some preventive measures that could have avoided certain accidents?

2. Do some research. Give a report on a tractor-related accident. Point out ways the accident could have been avoided.
3. Learn and practice the set of universal hand signals used to communicate with the tractor operator. Team up with a partner and take turns calling out conditions requiring the signals so you can learn to use them comfortably when needed.
4. Liquid fuel cannot burn. It must be vaporized and mixed with air. You can demonstrate this with a candle.

Light the candle and watch it burn for a few seconds. Notice how the paraffin first melts from a solid to a liquid and then is vaporized by the heat from the flame. When the candle is snuffed, the vapors that continue for a few seconds can be relighted some distance from the wick.

5. Sometimes it's difficult to know what to do in an emergency. In many instances, people tend to freeze and do nothing at all or make the wrong move. Here's an easy way to demonstrate this fact. Hold one end of a broomstick and ask another 4-H'er to grip the other end tightly with one hand and pull. Tell him to let go when he feels you jerk on the broom. After a second or two give a quick jerk on the handle. Chances are, your friend only tightened his hold and could not let go. A person's natural reaction is to tighten his grip and hold on. This is why so many people get caught in machinery or running

equipment. The machine suddenly unclogs itself and the operator can't let go, so the hand goes into the machine, or they wait too late to let go

and their clothing gets caught, pulling them into the machine.

Figure 1-4
THESE UNIVERSAL HAND SIGNALS ARE FOR COMMUNICATING UNDER NOISY CONDITIONS AND IN OTHER SPECIAL CASES.

Start the Engine: Move arm in a circle at belt level.



Stop the engine: Move your right arm across your neck from left to right.



Come to me: (Can also be come to me because I need assistance). Lift your arm vertically over your head with the back of your hand to the rear and turn your arm in large horizontal circles



Move out: Face in the needed direction of movement. Put your arm straight out behind you. Then, swing your arm over your head and forward until your arm is straight out in front of you with the back of your hand up.

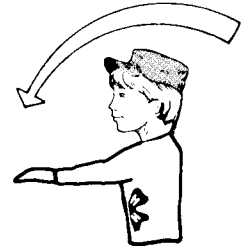

Move Toward Me or Follow Me: Look toward person or vehicle you need to move. Hold one hand in front of you with the back of the hand toward the vehicle and move your arm.

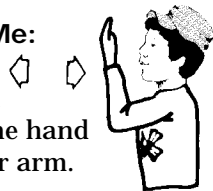

This far to go: Put your hands in front of your face with the back of your hands outward. Move your hands in or out as an indication how far to go.



Raise Equipment: Point up with one finger and at the same time, move your hand in a circle at head level.



Lower equipment: Point to the ground with one finger and at the same time move your hand in a circle.



Increase Speed: Lift your hand to shoulder.

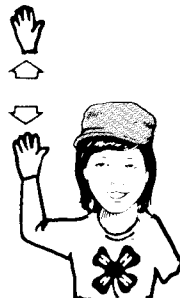

Decrease speed: Put your arm out horizontally with the back of your hand up and then move your arm down about 45 degrees minimum many times. Keep your arm straight and do not move your arm above your shoulder.



Stop: Raise your arm fully up with the back of your hand to the rear. Keep this position until the signal is understood.



Checking up on Safe Tractor Operation

1. What three conditions cause the most deaths attributed to tractor operations? State at least one measure for preventing each unsafe condition.

A. Condition: _____

Preventive Measure: _____

B. Conditions: _____

Preventive Measure: _____

C. Conditions: _____

Preventive Measure: _____

2. If the operator is cautious, a tractor may be started slowly while standing on the ground, as long as there are no implements attached. T F

3. All tractors should be equipped with seat belts and the operator should use them when in the tractor seat. T F

4. As a general rule, the tractor's PTO shaft does not become dangerous until it has developed at least one-half its rated power. T F

5. (A) Carbon dioxide (B) Carbon monoxide in exhaust gases can kill you.

RECORD KEEPING

It is extremely important that you service a tractor regularly and according to the operator's manual. Keeping records is a way of verifying services performed.

Records help guard against forgetting to perform services on time and they provide information to help you figure operating costs. Records do not have to be complicated. You simply write down the services performed when they are done and the cost of the supplies used.

The sample record forms in this unit are simplified but complete. They provide a record of operation and services performed and a record of fuel, oil and repair expenses. You can use these or any others which allow you to keep similar information. Facts you always want to note include: the date, number of hours operated, services performed, and any other notes or observations you wish to make.

Your operator's manual is an important guide to record keeping. Refer to the maintenance and service schedule. If you study the instructions carefully and keep those records faithfully, you'll be well repaid by savings in repairs, time and longer tractor life.

Servicing Forms

The first form (Fig. 2-1) contains a list of tractor services and the normal periods for doing these. Note that the services are grouped by how frequently they must be done. Below the listing of the services, spaces are provided for checking off the hours the tractor is used. Each square represents one hour of operation and there are 10 blocks or hours in each vertical line. The date should be inserted for the first hour of use.

Moving down the first column of blocks, enter a check mark for each hour of operation. On the next day of operation, begin a new series of blocks by entering the date in the next square.

Whenever a group of services is performed, that day insert the code letter for that group. If you look at the sample form here, you see that the tractor was used five hours each day on October 31 and November 1. The "A" services (10 hours) were performed. The next day, November 2, the tractor was used nine hours and, for the sake of convenience, it was serviced before being taken out for the next day's work.

From the chart you can see that for convenience the 50-hour check-up and servicing were

given at 49 hours. At this time all the services listed for the 50-hour or "B" periods were completed, as well as those for the 10-hour "A" service. The same applies to the other service periods. Each time you do the "C" services you do the "A" and "B" services, and so on.

Figure 2-1
A SERVICING RECORD FORM AND SAMPLE ENTRIES FOR A TRACTOR.

WORK UNIT
Second Year Unit 8

TRACTOR RECORDS AND OPERATING COSTS

RECORD OF HOURS AND TYPES OF SERVICES PERFORMED

A 10 Hrs. CHECK ENGINE OIL LEVEL
CHECK WATER IN RADIATOR
SERVICE AIR FILTERS
CHECK TIRE TRACTOR
CHECK TIRE BATTERY

B 20 Hrs. LUBRICATE FLUID BEARINGS
CLEAN RADIATOR FINS
ADJUST TIRE PRESSURES
CHECK FUEL VALVE
CLEAN BURNER
CLEAN AIR CLEANER ELEMENT
OIL SERVICE AND GENERATOR

C 100 Hrs. CHANGE TRANSMISSION OIL
CLEAN OIL PAN
CHECK THE CLUTCH
CHECK TRANSMISSION OIL
CHECK OIL FILTER
ADJUST SPARK PLUGS
ADJUST VALVE TAPPETS
INSPECT BRAKES

D 200 Hrs. CHECK FRONT WHEEL BEARINGS
FILL FUELING SYSTEM
CLEAN AIR CLEANER ELEMENT
CLEAN FUEL SYSTEM
CHECK GOVERNOR ADJUSTMENT

E 100 Hrs. CHECK FRONT WHEEL BEARINGS
FILL FUELING SYSTEM
CLEAN AIR CLEANER ELEMENT
CLEAN FUEL SYSTEM
CHECK GOVERNOR ADJUSTMENT

F 750 Hrs. OIL SERVICE AND GENERATOR
TIGHTEN BOLT
OIL AND REPLACE TRANSDUCER
INTERNAL AND DEFLECTOR TO
MAINTAIN TRACKING

This is an example of how the upper portion of the form might be filled out, and how the lower portion might be checked (through the first "C" service only shown here). In the lower portion each small square stands for one hour of tractor operation; each vertical row represents ten hours or a tractor-day's work.

Record of Hours and Types of Services Performed

A	Hrs.	_____	C	Hrs.	_____
		_____			_____
		_____			_____
		_____			_____
		_____			_____
B	Hrs.	_____	D	Hrs.	_____
		_____			_____
		_____			_____
		_____			_____
		_____			_____
	Hrs.	_____	E	Hrs.	_____
		_____			_____
		_____			_____
		_____			_____
		_____			_____
	Hrs.	_____	F	Hrs.	_____
		_____			_____
		_____			_____
		_____			_____
		_____			_____

50 HRS.	100 HRS.	150 HRS.	200 HRS.	250 HRS.
---------	----------	----------	----------	----------

FUELS AND LUBRICANTS

A tractor won't run without fuel, oil and other lubricants. And it won't operate properly and efficiently unless the correct products are used. Let's look at how these products are classified and when to use them.

When you use the correct fuel in a properly maintained engine, you can help ensure that your tractor will produce all the power for which it was designed. Greases and oils enable the tractor to operate efficiently, and they help prolong engine life by cutting down on wear.

It is important for you to know which fuels and lubricants are well suited for certain operating conditions. Review your operator's manual for specifics.

Fuels

Diesel. Reliable suppliers provide diesel fuel formulated for high-speed diesel engines, such as those in tractors, other farm machinery and industrial engines.

Your operator's manual specifies that any recommended diesel fuel have a minimum "cetane" number. This is a measure of the fuel's ability to self-ignite. The higher the cetane number, the better the fuel self-ignites when heated. Remember that the diesel engine has no spark plug. The fuel must self-ignite from heat of compression immediately after it is injected into the cylinder.

Most modern diesel engines for tractors and other heavy equipment are designed to operate on fuels with cetane numbers between 40 and 60. Even a good diesel fuel still may not self-ignite rapidly in cold weather. Ether, with a cetane number of perhaps up to 95, is sometimes used to assist in cold weather starting. However, do not use ether for starting diesel engines unless it is recommended by your tractor manufacturer.

Gasoline is available in many mixtures: "regular," "unleaded," "premium," and "super premium." Your operator's manual will tell you which grade to use in your tractor.

The major differences (except for adding lead) between the gasoline grades mentioned depend on the octane number of the fuel. The octane rating measures the ability of the fuel to prevent "knocking." Lower octane fuels will knock in high compression engines because they are not formulated to be compressed so much. Knocking occurs when fuel ignites unevenly in the combustion cylinder. Instead of burning evenly, the fuel mixture, in effect, explodes. This causes excessive and uneven

forces which the pistons, valves and bearings are not designed to absorb. If knocking continues, it can seriously damage internal engine parts.

Gasohol is a mixture of 90 percent unleaded gasoline and 10 percent ethanol (grain alcohol). It is available in some areas as a substitute for gasoline. Ethanol contains less energy per gallon than gasoline. An engine will develop more power from ethanol only if it is designed and tuned for a higher octane fuel.

LP-Gas is available for use in farm tractors. However, it is not very popular because it requires special equipment to transfer it into the tractor fuel tank. It is a clean burning fuel and LP engines require fewer repairs than gasoline or diesel engines.

Engine Oils

Many engine oils are available to the consumer. It may seem difficult to choose the correct one for your tractor. But if you know the standard system of classification you can be sure you are always using the proper oil.

After motor oils are refined, they are given many tests so that manufacturers know they are making a uniform product.

Viscosity Classifications: The viscosity test is one of the most important ones for the user. Viscosity tells how well the oil flows at different temperatures. You have probably heard people speak of a "light" or "heavy" oil. They are referring to viscosity.

Figure 3-1
MULTI-VISCOSITY OILS REPLACE SEVERAL SINGLE-VISCOSITY OILS.

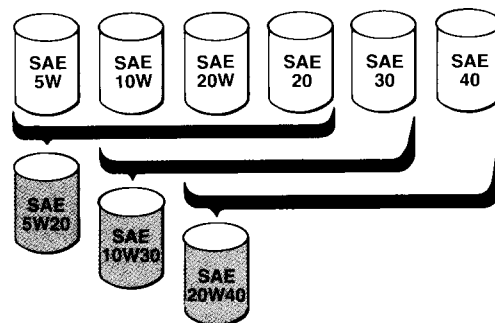

Oils with additives to provide good low temperature properties and prevent too rapid thinning when heated are classed as multigrade oils (Fig. 3-1). Such oils are listed as 5W-20, 10W-30, 10W-40 or 20W-40. These are well suited to start-and-stop

operation. They are especially useful for seasons in which extremes of warm and cold temperatures occur.

The SAE grade of oil to use in your tractor depends on crankcase temperature and engine design. An oil with a low SAE number is a thinner oil and an SAE 40 is a thicker oil.

Service Classifications: Engine oils also are classified according to the suitability of service. These classifications, which tell the “quality” of the oil, have been developed by the American Petroleum Institute (API).

Current API classifications have either the prefix “S” for service station engine services or “C” for commercial and fleet engine applications. It’s easy to remember that S categories are mainly for spark-ignition engines while C categories are for diesel engines.

A second letter denotes the sequence of performance tests a motor oil has passed. The simplest service categories are SA and CA. Motor oils meeting specifications for these categories offer little more than basic lubricating properties. Such motor oils would offer little protection in today’s modern, high-performance engines. As performance requirements become more complex, motor oils are improved to meet or surpass engine protection needs (Fig. 3-2).

Figure 3-2
NEWER MOTOR OILS ON THE MARKET USUALLY MEET OR EXCEED MORE THAN ONE API SERVICE CLASSIFICATION.

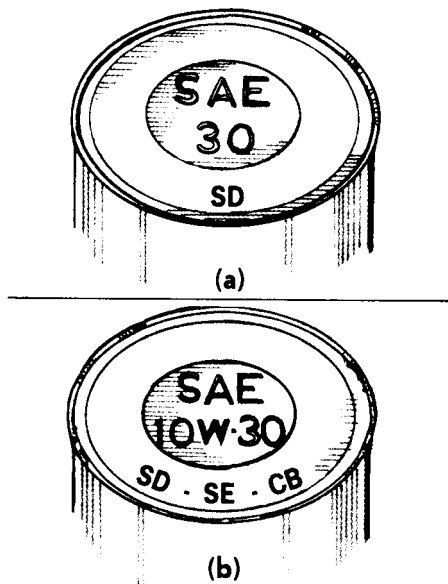

Each time a new series of tests is developed, the second letter is changed in the API classification. Thus, motor oils passing the SF and CD test sequences are the “best” oils available, in terms of

protection they offer the engine (Table 3- 1). Always use a grade carrying the same or higher API classification of oil specified for your tractor. For example, CD quality oil may be used to replace CC quality.

Table 3-1
API Service Designations for Engine Oils

SAE Letter Designation	API Identification of Engine Service
SA	Utility Gasoline and Diesel Engine Service
SB	Minimum-Duty Gasoline Engine Service
SC	1964-67 Gasoline Engine Warranty Service
SD	1968-71 Gasoline Engine Warranty Service
SE	1972 Gasoline Engine Warranty Service
SF	1980 Gasoline Engine Warranty Service for many Automotive Applications
CA	Light-Duty Diesel Engine Service
CB	Moderate-Duty Diesel Engine Service
CC	Moderate-Duty Diesel and Gasoline Engine Service
CD	Severe-Duty Diesel Engine Service

Lubricants

Gear lubricants are classified in the same way as engine oils — by viscosity and service classification. While they resemble the thicker engine oils, they perform different jobs in the transmission, differential, final drive units or power take-off.

Gear oils range from the simple, for use in older systems, to hydraulic-type lubricants for use in newer machines. These newer gear systems usually have smaller, stronger gears able to withstand tremendous loads that produce high pressures and friction between the moving parts.

Grease is a solid or semi-solid lubricant, usually a lubricating oil with a thickener and sometimes other additives. The thickener is often a type of soap.

Different greases were needed to lubricate various parts of the tractor years ago. The newer multi-purpose greases usually are suitable for almost any tractor application.

Synthetic Lubricants. Ordinary lubricants are produced by refining mineral (petroleum) oils to the desired quality and adding any other compounds to meet specific performance requirements.

In recent years, many manufacturers have introduced “synthetic” lubricating products. These fluid lubricants and greases are made by building up or synthesizing a product (usually petroleum product) for a specific purpose.

Manufacturers claim that the greatest advantage of synthetics is their longer service life. A synthetic oil, for example, may perform effectively for four times as long as a mineral-based oil. These newer oils also remain viscous at much lower temperatures than a mineral oil of the same SAE number.

Synthetic products carry the same SAE and API classifications as mineral-based products. Check with your tractor dealer to be sure synthetic products can be used on your tractor. This is especially important when systems are under a manufacturer’s warranty.

Learn by Doing

1. Visit your local service station, farm supply outlet or tractor dealer. Make a list of the

various lubricants available. Compare your list with the lubricants recommended in your tractor operator’s manual. How many of those available may be substituted to meet the tractor’s requirements? Which ones are unsuitable and why?

2. Obtain some automobile or tractor engine parts that have been replaced because they are badly worn. Try to determine whether poor lubrication was a major contributor to their failure. You might want to obtain an estimate on the cost of replacing the parts, if you can. Make a display so others can see how important proper lubrication is.
3. Tape record an engine “pinging” and use it in a presentation at your club meeting.
4. Take a sample of oil and divide it into three samples. Place one in a deep freezer, warm one in an oven, and leave one at room temperature. Punch a hole in a can. One at a time, compare the time necessary for an ounce of each to drip through the hole in the can.

Checking up on Fuels and Lubricants

1. Why is ether sometimes recommended for helping start a diesel tractor in very cold weather?

2. Match the lubricants in the left column with the characteristics in the right column which best describe their viscosities.

SAE 10-40 engine oil
 SAE 120 gear oil
 SAE 50 engine oil
 No. 5 lubricant

Does not flow at normal temperatures.
 Flows well over a wide range of temperatures.
 Not viscous enough for cold weather engine operation.
 Similar to slow-flowing engine oil.

3. You have just purchased a new diesel tractor. Your operator’s manual would specify an engine having at least the _____ service designation.

(A) CA (B) SF (C) CD (D) SD

4. An engine oil carrying the SA specification will last longer than one having the CD specification.

T F

5. So-called synthetic lubricants last longer in an engine because they contain special nonpetroleum chemicals.

T F

6. “Regular,” “unleaded,” and “premium” are terms used to distinguish between types of

A) ethanol, B) gasoline, C) natural gas?

7. Always use a grade of oil carrying A) higher/same, B) lower/same API classification, as specified in your operator’s manual?

FUEL SYSTEMS

You will remember from your earlier tractor studies that gasoline, LP-Gas and diesel engines get their names from the fuels they use and all have different fuel systems. But there are basic similarities. A tank stores the fuel, one or more pumps transfer the fuel, and the injectors (diesel engines) or carburetors (spark-ignition engines) atomize the fuel so it burns easily. Fuel systems also include lines and filters to transport and clean the fuel, and serve as a means of providing large quantities of clean air for mixing with the fuel. (See Fig. 4-1.)

**Figure 4-1
BASIC FUEL SYSTEM.**

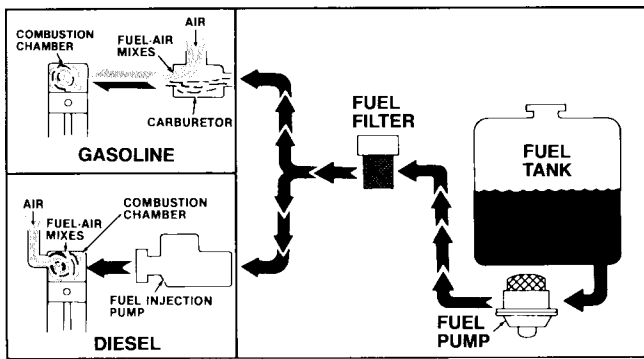

Diesel Fuel Systems

Injection Pump. Most diesel engines on farm tractors have two fuel pumps. A fuel transfer pump forces fuel under low pressure from the tank to the injection pump. The injection pump puts the fuel under high pressure (from 1,900 to 5,000 pounds per square inch) and distributes it to each injector. The transfer pump delivers fuel to the injection pump.

Many makes of diesel tractors use a distributor injection pump (see Fig. 4-2). It features an engine-driven driveshaft which imparts rotary motion to pump components. The fuel transfer pump at one end of the shaft supplies fuel under low pressure through the rotor. Fuel is pumped to the injection nozzles by two pistons or plungers working toward each other.

A diesel engine does not have a choke to assist with cold starts. Some diesel tractors have a means for injecting a starting fluid during cold weather. Starting fluids often are ether, which volatilizes to a gas and ignites easily. These fluids are highly explosive and only work at temperatures down to 0°F. At temperatures below 0°F an electric supplemental heater mounted in the cooling system is needed.

**Figure 4-2
MAIN COMPONENTS OF A DIESEL FUEL SYSTEM (DISTRIBUTOR TYPE SHOWN).**

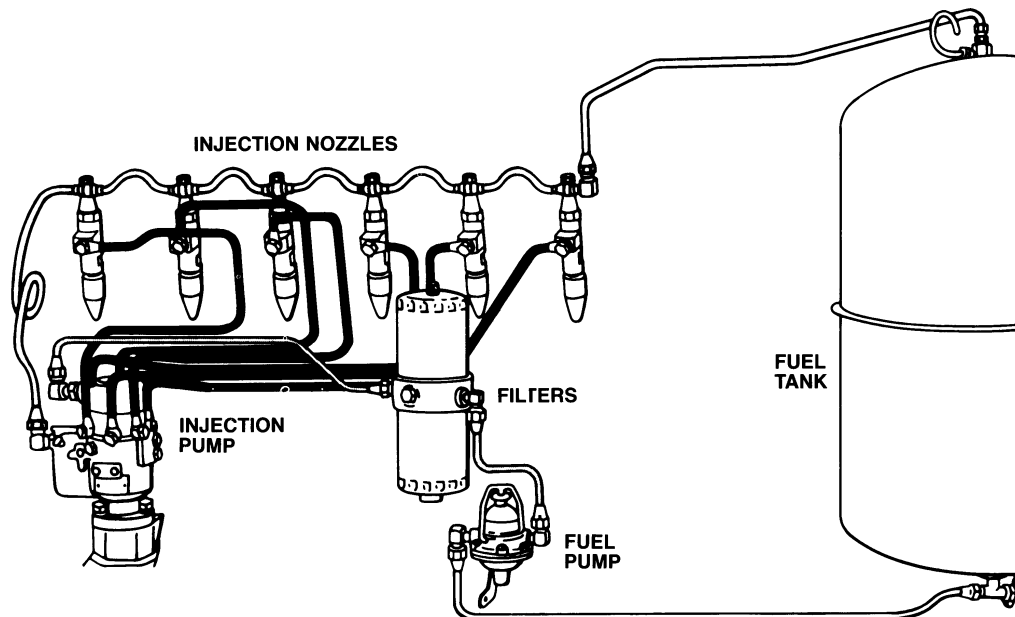

Do not use ether unless recommended by your tractor manufacturer. If recommended, follow the instructions carefully. Consult your operator's manual.

When the plunger mechanism increases the fuel pressure to the injector, the additional pressure overcomes the spring force and the valve opens. Fuel is injected into the combustion chamber until the fuel pressure inside the nozzle becomes lower than the spring's.

The **governor** operates the injection pump control valves and varies the amount of fuel supplied to the engine. This control helps maintain a constant engine speed once the speed is set by the operator. In most diesel fuel systems the governor is part of the fuel injection pump and is not serviceable.

Maintenance

Water and dirt are the enemies of any fuel system — especially the diesel system. Fuel systems on tractors have one or two places to remove water and two or three places to remove dirt or other solids. Check your operator's manual so you will know where and how often to service these.

You have already learned how to store fuel correctly to help keep out water and dirt. Nevertheless, water can still condense in the fuel tank, if the tank is not kept full during cool weather. Most tanks, therefore, have a drain valve underneath so any water (and dirt) can be removed. The fuel transfer pump normally has a second water trap and a strainer filter to stop any larger pieces of dirt.

Most diesels have two more filters between the transfer pump and the injector pump. They are often called the primary and secondary fuel filters and are usually canister-type.

Your operator's manual has details for servicing the transfer pump filter and any additional filters in the fuel lines. Be sure to tighten them securely during reassembly to prevent air, water and dirt from entering the system later.

Bleeding the Diesel System

The diesel fuel system cannot operate with air in the fuel lines. Air can get into lines in several ways: (1) if the tractor runs out of fuel during operation; (2) when fuel filters are changed; (3) when any part of the system is repaired. Any air inside the lines must be removed by "bleeding."

Bleeding procedures vary for each diesel engine (Fig. 4-3). Your operator's manual shows the steps necessary for your tractor. To bleed the fuel system, work from the fuel tank toward the

engine. Generally, you must first ensure that the fuel tank contains clean fuel. Then open one or more bleeding screws or ports (often located on or near the filters) until no air bubbles show in the escaping fuel.

Figure 4-3
ONE TYPE OF ARRANGEMENT FOR BLEEDING A DIESEL FUEL SYSTEM ON A TRACTOR.

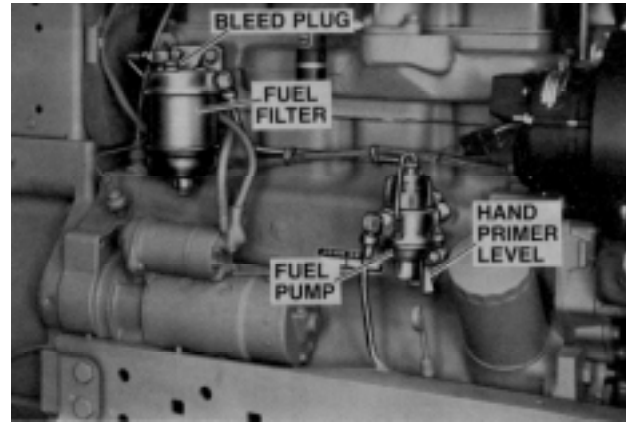

Spark-Ignition Engines

In spark-ignition systems, both fuel and air are metered and supplied together to the combustion chambers (see Fig. 4-4). The carburetor is the precision part of the spark-ignition fuel system which mixes the fuel and air and supplies the correct amount for combustion.

If too little fuel is supplied, it's called a "lean" mixture. A lean mixture burns slowly and does not give full power. The exhaust gas temperature of a lean mixture due to slow burning is so hot that it can cause valve trouble. On the other hand, if too much fuel is allowed to enter the engine a "rich" mixture results. This wastes fuel and causes deposits on the spark plugs and other engine parts because of incomplete combustion.

The carburetor works like an insect spray gun. As you pump a spray gun, air passes over a little tube that leads up from the insecticide can. The speed of the air over the tube creates a vacuum and liquid comes up from the can. The force of the air then breaks the liquid into a fine mist, atomizing it.

In the engine, the piston intake stroke creates a vacuum in the cylinder. Air rushes in. The incoming air goes through the air cleaner and through the carburetor to the combustion chamber of the engine.

If the carburetor is properly adjusted, you should not need to change the settings. If you think the engine is not operating correctly, check the troubleshooting section of your operator's manual. Many problems blamed on the carburetor actually are caused in the ignition system or are the fault of a poor supply of fuel or air.

Figure 4-4
ARRANGEMENT OF COMPONENTS IN A GASOLINE FUEL SYSTEM — SPARK-IGNITION ENGINE.

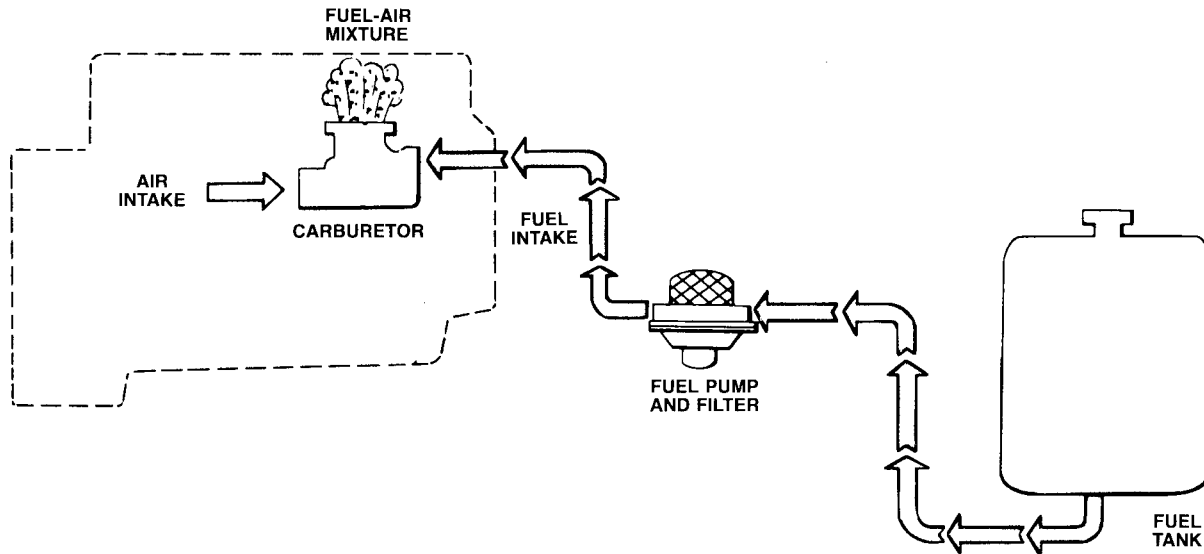

You may be able to adjust the idling speed, the idling mixture and the load mixture by carefully following the steps outlined in the operator's manual. But remember, if you are not experienced in working on carburetors, have an experienced person help you, or have a trained person make the adjustments.

The **governor** (see Fig. 4-5) on a spark-ignition engine acts in much the same way as the one on a diesel. The governor is used to regulate engine speed and rotation.

The engine turns weights on the governor. As the weights rotate they tend to fly outward. Because the weights are connected to the throttle valve of the carburetor, the throttle closes as the weights move outward. Tension on the governor spring controls the distance the weights can move. If the spring is tight, the engine must run faster to throw the weights out the same distance. Increasing the spring tension, by advancing the throttle lever, thus makes the engine run faster. By balancing the pull of the weights against the spring, the engine is kept running at whatever speed it is set to run.

Engine Air Supply and Cleaners (Filters)

Just as engines must have clean fuel, so must all of the air used in combustion be cleaned carefully. Several types of filters can be used to clean the air for tractor engines. Maintaining the filters so they do their jobs correctly is an important task. Once again, an adult or dealer-mechanic would be your best bet the first time you tackle this task.

Most older tractors use an **oil bath cleaner** (see Fig. 4-6). It has a screen that is automatically washed with oil. The air coming down through the

air intake stack passes over the surface of the oil held in the small cap. Some of the oil is carried up

Figure 4-5
GOVERNOR SPRING & LINKAGES.

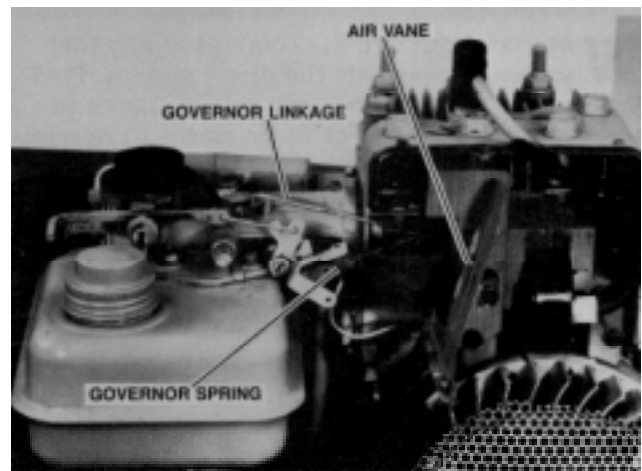
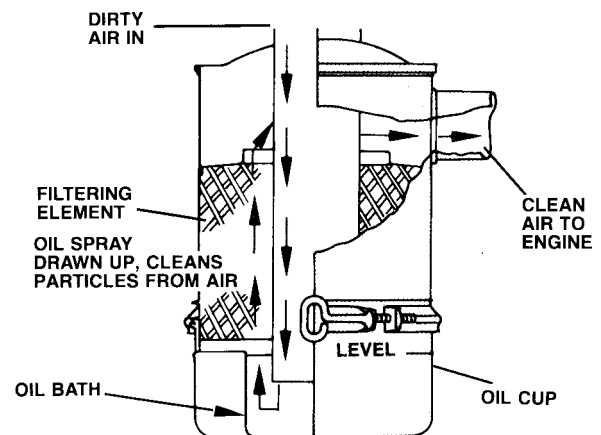

Figure 4-6
OPERATION OF AN ENGINE OIL BATH AIR CLEANER.



into the separating screen; then it drains back into the cup. This process keeps the separating screen oiled and washes the dirt back into the cup. The fine dust not trapped when the air passes over the surface of the oil will be caught by the oil film in the separating screen. The cleaned air flows on into the engine.

Most late model tractors have **dry-type air cleaners** which use a paper element in place of an oil bath for removing the dust. The element is made of special paper and must be replaced periodically so that air flow to the engine is not restricted. A restricted air intake causes power loss and increased fuel consumption. On a diesel engine, a restricted air cleaner will cause smoking and loss of power. A severe restriction will also cause a gasoline engine to smoke.

One dry-type air cleaner has an automatic dust unloader and pre-cleaner to continually remove larger dust particles (see Fig. 4-7). Another type is built like an oil bath cleaner. It collects the dust in a cup which must be emptied as the dust builds to a given level.

The **aspirated air cleaner** is a newer type of device used as a pre-cleaner. The pre-cleaner consists of a swirl chamber that is connected to the muffler or on the exhaust pipe. Suction pulls the dirt from air in the swirl chamber and out through the exhaust pipe.

Servicing Air Cleaners

To check an **oil bath cleaner**, remove the oil cup and look at the oil. If it is very dirty, clean and refill it. Be sure to use the oil specified in your manual and to fill the cup to the correct level. While you have the cup off the air cleaner, examine the wire mesh or separating screen. Make sure the bottom of that screen is not covered with trash or chaff. Clear the air passage from the pre-cleaner into the oil cup periodically. Oil bath air cleaners should be checked daily, or more often, when operating under dusty conditions.

Be sure all hoses and connections in the intake system are in good condition and tight. Leaking hoses and clamps let in enough dirt to ruin an engine.

Knowing when to service a **dry air cleaner** is important. Underservicing can cause engine wear and loss of power. Overservicing can let dirt enter the engine each time the filter is removed. It also can damage the elements. Most tractors have an indicator to show when the filter should be serviced. The indicator may be located on the intake system or it may be a light located on the instrument panel. Check your operator's manual for how and when to inspect and service the dry element.

Some paper elements are cleaned by gently tapping the filter element with the heel of your hand. Then apply low pressure compressed air to the element, using a filter cleaning adaptor on the air hose. In other cases, it may be best to wash the element in special detergent. Then let the element dry thoroughly before installing.

Figure 4-7
TWO METHODS OF REMOVING DUST WITH PRE-CLEANERS AND DRY-ELEMENT AIR CLEANERS.

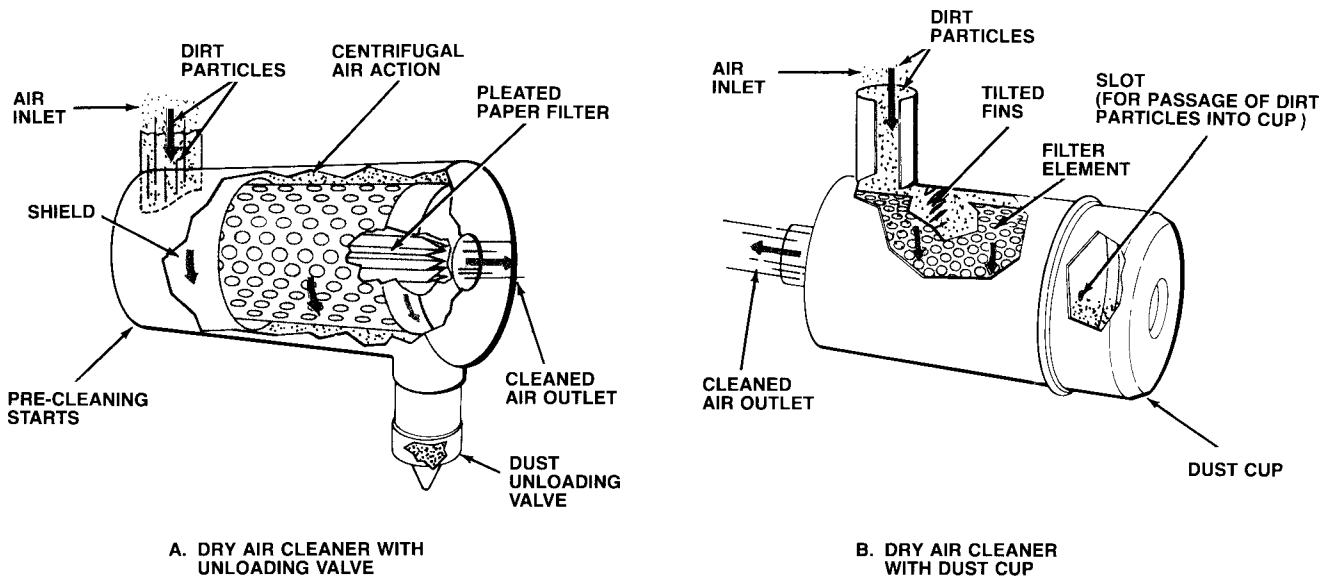

Learn by Doing

1. Describe the steps required to bleed air from a diesel fuel system. If a tractor is available, ask an adult familiar with the procedure to help you bleed the system.
2. Fuel a tractor. Review operator's manual then actually fuel a diesel and a gasoline engine. How are they similar? Different?
3. How do you know when it is time to service the air cleaner system on a tractor? Perform this maintenance procedure. Ask an adult to be present in case you have a problem.
4. Clear the fuel storage area. Bury or burn old rags and other dangerous items that can cause a fire.

All tractor fuels burn readily. Clean up all spilled fuel immediately after refueling.

Checking up on Fuel Systems

1. How do dirt and water affect the parts of a diesel fuel system? _____

2. What is one possible cause of smoking from a diesel and a gasoline engine?
How can the condition be corrected?

3. The injector on a diesel engine is comparable to the carburetor on a gasoline engine; both provide the proper air/fuel mixture to the engine. T F
4. A high-speed stream of air flowing through the carburetor is used to pick up and vaporize fuel in a spark-ignition engine. T F
5. Oil bath cleaners on tractors use lubricating oil from the engine to help filter the air. T F

LUBRICATING THE TRACTOR

Regular lubricating with proper lubricants is necessary for long life and trouble-free operation of your tractor. Your operator's manual will show some type of lubrication guide for your tractor model. The manual will also specify the proper lubricants to use and how to check and apply them.

Engine Lubrication

Modern engines use an oil pump to circulate the oil. The most common pump has a small set of gears which picks up the oil from the oil pan reservoir and puts it under pressure. A screen on the suction side of the pump removes large particles that might otherwise damage the pump. Much more oil is pumped than is needed and the surplus flows through a bypass valve or pressure regulating valve back to the crankcase.

An oil pressure gauge or light on the instrument panel indicates whether the pump is putting the oil under pressure in the line. In fact, some of the lines could be plugged and you would not know the difference by looking at the gauge. It would merely show pressure. This is one reason why it is so important to service the engine oil and filters on time.

Some engines have small pipes and holes in the crankshaft which lead to all bearings. Such an arrangement is called a full-force feed system (see Fig. 5-1). With this system, if the bearings become loosened or worn, the oil pressure may drop. Lowered pressure is most likely to be noticed if the engine is operated at slow speed. Loose bearings will let more oil escape and this oil will be thrown up on the pistons. Such a condition is a common cause of high oil consumption.

Figure 5-1
A FULL-FORCE FEED LUBRICATION SYSTEM FOR A TRACTOR ENGINE.

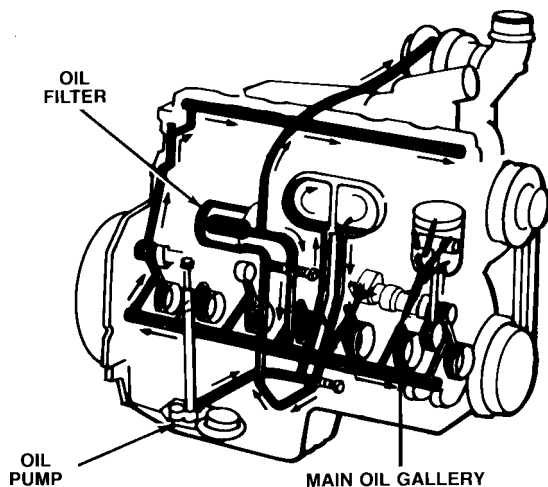

Another oiling system popular in older, smaller tractor engines is the circulating splash system (see Fig. 5-2). Oil is pumped to a dip trough or squirted through holes in an oil line to the rod bearings.

Figure 5-2
A CIRCULATING SPLASH LUBRICATING SYSTEM.

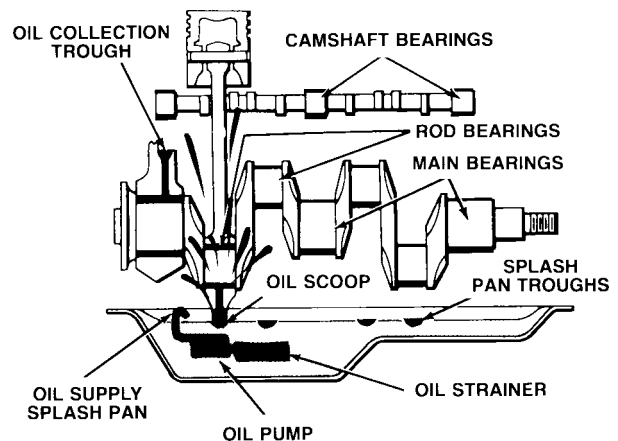

Oil Filters & Systems

The most common type of filtering system found on modern tractors is the full-flow oil filter. This filter receives all of the oil as it leaves the oil pump and filters out contaminants before the oil reaches the bearings. Oil and filters must be changed regularly at the intervals specified in the operator's manual to avoid clogging the filter. Many oil filtering systems contain a filter bypass which allows oil to flow past a clogged filter and still lubricate engine parts. However, if the oil is dirty enough to clog the filter, it is too dirty to effectively lubricate engine parts.

Filters usually are changed with each oil change. Always use the type specified for your engine. Some filters are mounted inside a canister and secured with bolts. Spin-on type filters also are common. To mount a spin-on filter, put a thin film of clean engine oil around the rubber gasket on the filter face and turn the filter onto the mounting until you feel the gasket just making contact. Tighten the filter by hand an additional amount specified in your instructions (usually one-half to three-quarters of a turn). Do not over-tighten by using a filter wrench; this could damage the gasket and its seal.

After changing the oil and replacing the filter, always run the engine a short time. Check for leaks around the crankcase drain or the filter.

Servicing the Lubrication System

It's not difficult to service the lubrication system. The important thing is to service it on time, according to your operator's manual.

The oil level is always checked daily. This is done with the "dipstick" (see Fig. 5-3). If checked at the end of the day, be sure all the oil has drained back into the crankcase after the engine has been shut off. When adding or changing engine oil, always use the type specified for your engine and the local operating conditions. You should change the engine oil immediately following a daily operation, while the oil is still warm and impurities are in suspension.

Figure 5-3
THE DIPSTICK IS USED TO CHECK THE ENGINE OIL LEVEL DAILY.

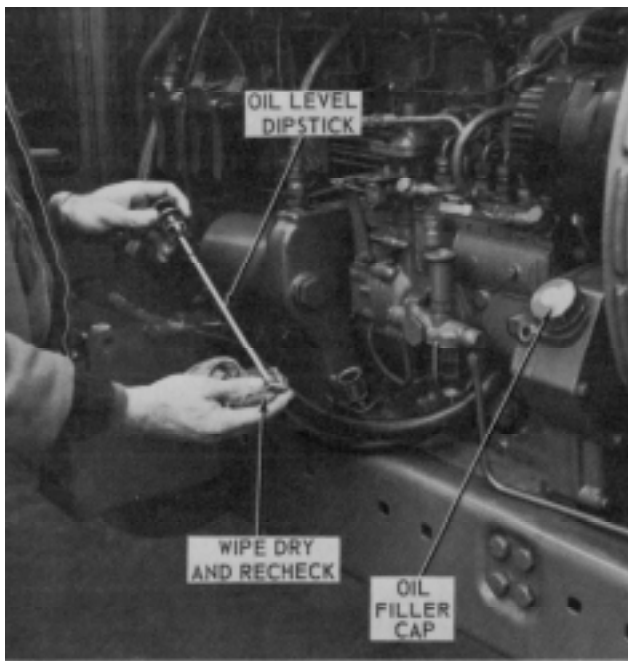

Greasing the Tractor

Your tractor has several points equipped with grease fittings which must be serviced regularly (see Fig. 5-4). The most common locations are around the front and rear axles. Follow the detailed diagrams and instructions in your operator's manual.

Always be sure to wipe off the fitting before attaching a grease gun. Hold the gun as much in line with the fitting as possible so a good seal is made. Remove the gun by moving it through a slight arc. Be careful not to apply too much pressure or grease to any bearings having seals; you might break the seal. This will allow grease to escape and water and dirt to get in the bearing. A few strokes with a

Figure 5-4
THE OPERATOR'S MANUAL SHOWS WHERE ALL GREASE FITTINGS ARE LOCATED AND TIME INTERVALS FOR LUBRICATION.

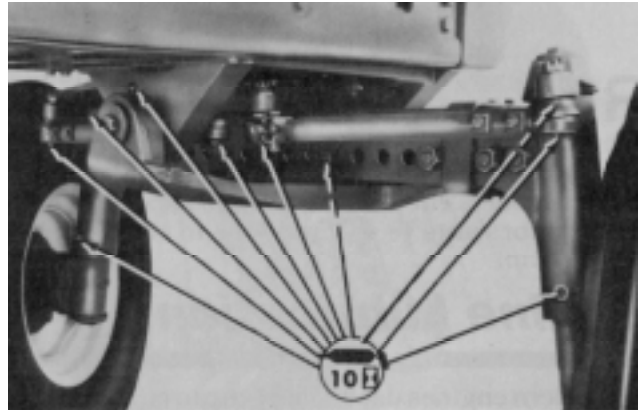

large hand gun are usually enough. Finally, grease at the end of the working day. Fittings are still warm and take the grease better.

Be especially careful in handling greases. Always keep the grease indoors so dirt and water can't get in.

When greasing ball or roller bearings (such as front wheel bearings) by hand, remember that it is the grease within the bearing that will actually lubricate it. A typical wheel bearing assembly is shown in Figure 5-5.

Figure 5-5
BEARINGS ON A SPINDLE WHEEL ASSEMBLY.

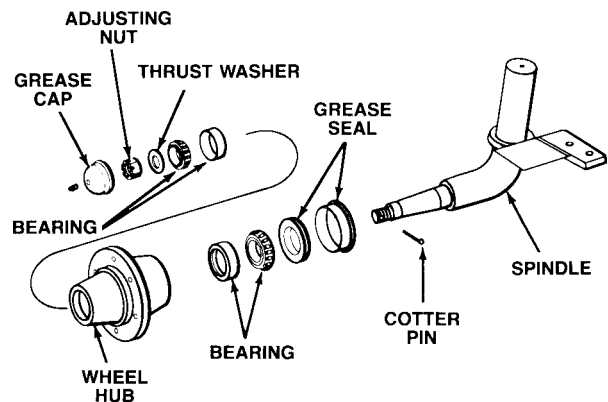

Before packing the bearing, clean it carefully by washing it in solvent, then allow it to dry. Then dip the bearing in oil and allow it to drain for a short time. A film of oil in the bearing makes it easier to get the grease into it. The oil soon mixes with the grease.

Follow these steps to pack a ball or roller bearing. First, place about one-half cup of clean, fresh grease in the palm of your hand. Hold the bearing by one side and "bite" it into the grease to force the grease upward through the bearing

retainer and inner cup (see Fig. 5-6). Rotate the bearing and continue to take bites of grease until you have worked all the way around the bearing. The new grease should be squeezed up through the bearing and out the top between the rollers.

Figure 5-6
WHEEL BEARINGS MUST BE CAREFULLY
PACKED WITH GREASE.

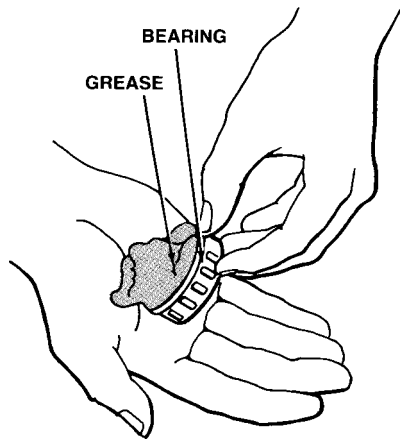

Lubricating Other Systems

The transmission, the final drives and the hydraulic system are some other systems requiring

regular lubrication. These will be discussed in Lessons 8 and 9 in this manual. Meanwhile, don't forget to check and service these systems as indicated in your operator's manual.

Learn by Doing

- 1.** Review the manufacturer's instructions for checking and changing the engine oil in your farm or garden tractor. If you are not sure of the procedures, ask a knowledgeable adult to help you. When you have mastered the procedures, ask if you can be responsible for regularly changing the oil.
- 2.** Take an inventory of the lubricants required for any machinery around your farm or home. Estimate the quantities needed for a given period (monthly, etc.). Purchase lubricants ahead of time so that they are available when needed.
- 3.** Greasing the tractor is an excellent activity for a 4-H member. Follow the operator's manual and write down the date and engine hours for future reference.
- 4.** Drain a sample of engine or transmission oil and pass a magnet through the sample. Inspect for metal filings. Send a sample into a testing laboratory and review the results with the owner and with a mechanic.

Checking up on Lubrication

1. The engine oil level of the tractor should be checked
(A) every 15 operating hours (C) whenever the oil pressure warning light comes on
(B) daily (D) under any of the above conditions
2. A new oil filter should be tightened to the manufacturer's recommendations by using
(A) a torque wrench (B) a special filter wrench (C) your hands
3. The oil pressure warning light or gauge on the tractor indicates whether
(A) the oil level is adequate (C) oil pump pressure is adequate
(B) oil pressure is adequate throughout the system (D) all of the above
4. When a hand-operated gun is used to lubricate grease fittings,
(A) a few strokes usually provide enough grease
(B) grease until you can see the old grease pushed out around the sealed area
(C) grease until you feel a definite resistance within the fitting
5. Describe briefly when, during the operational day, the following procedures should be done for best results.
(A) lubricating grease fittings _____
(B) changing an oil filter _____
(C) changing engine oil _____
(D) checking oil level after oil pressure light has been on during operation _____

6. List any other systems which require lubrication on your tractor _____

ELECTRICAL SYSTEM

The electrical system makes it possible for the engine to start. This system consists of three important circuits — the starting circuit, the ignition circuit and the charging circuit. The *starting circuit* converts electrical energy from the battery into mechanical energy needed to crank the engine. The *ignition circuit* creates the spark which ignites the fuel-air mixture to power gasoline or LP-Gas engines. The *charging circuit* recharges the battery and generates current during operation. How do all these things happen? Yes, through electrical circuits.

A simple electrical circuit consists of a conductor (a wire or some other body through which electricity can pass) and a source of electrical energy (a storage battery, for example). If the conductor is connected to the two terminals of the battery, electricity will flow from one terminal through the wire to the other battery terminal. If devices, such as motors or light bulbs, are placed within the circuit by properly connecting them to the conductor, useful work is done. If a switch also is wired into the circuit, it can be used to control when and for how long the work is done.

The component of the electricity doing the work is called “current,” the charge itself. Current is forced through the conductor by electrical pressure or “voltage.” All along the circuit the current meets “resistance,” which attempts to restrict current flow.

In this lesson we will be concerned with three main circuits—starting, ignition and charging circuits. You will find many other circuits on most tractors. Some of these include the lighting circuits; certain controls, sensing devices and gauges; and even circuits for radios and air conditioners. However, let's begin with the battery.

Figure 6-1
INTERNAL CONSTRUCTION OF A WET-CELL STORAGE BATTERY.

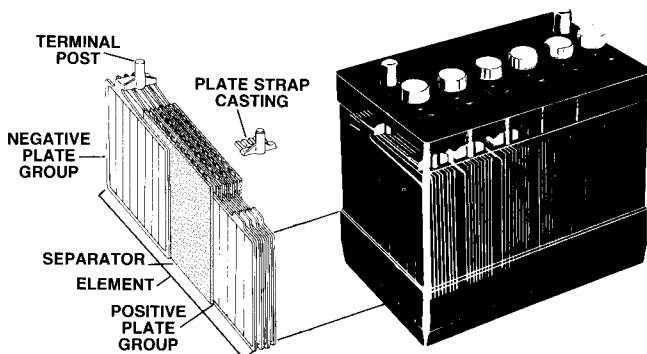

The Battery

The battery is the heart of the tractor's electrical system. A battery has a number of positive (lead) and negative (lead oxide) plates held apart by thin strips called separators (see Fig. 6-1). Each group of plates is called a cell. The cells are connected and held together in a hard rubber or plastic box. Each cell in this type of battery produces a little more than two volts of electrical force. A six-cell battery can produce a little more than 12 volts. Connecting two six-volt batteries in series also gives 12 volts. Twelve-volt electrical systems are common on modern tractors. Some large tractors have two 12-volt electrical batteries in series or in parallel to provide 24 volts for the starting circuit (see Fig. 6-2).

Figure 6-2
BATTERIES MAY BE CONNECTED TO PROVIDE ADDITIONAL ENERGY.

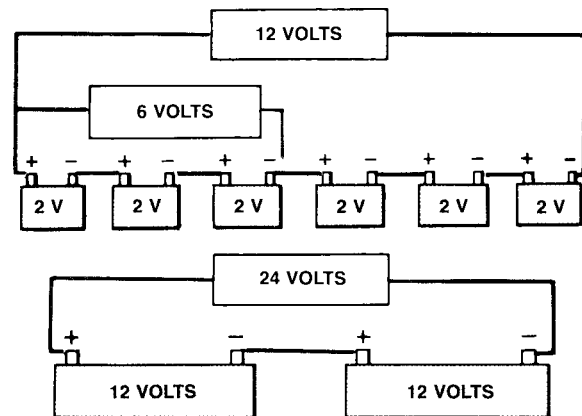

Caring for the Battery

A few simple measures will help ensure that the battery lasts for at least as long as it was designed. First, older batteries must have water. In hot weather when the tractor is used heavily, water evaporates from the battery fluid (electrolyte). The water level should be checked frequently (at least every 50 hours). Add only clean, soft water (if you have it, distilled water is ideal).

Some batteries are sealed and do not require the water to be checked.

The battery cable connection should be kept clean of dirt and corrosion. Clean connections will help provide good contact with the battery posts. Dust and dirt can be wiped from the battery with a damp cloth. Be sure, however, to keep the cap on the cells to prevent dirt from getting inside the battery.

To clean dirty battery connections, sprinkle a little baking soda on the corroded area and mix with a small amount of water (just enough to make a paste). Brush the mixture around until the fizzing stops, then flush the grime off gently with water. When replacing the cables, a little grease or petroleum jelly spread over the connections will help prevent more corrosion.

Finally, be sure connections are tight. Check to see that the battery is clamped firmly in its carrier frame. Don't fasten the bolts too tightly—you could crack the battery case.

Charging the Battery

During normal operation of the tractor, the charging circuit keeps the battery charged. It is possible, however, for the battery to become discharged. This could happen if the charging circuit is defective, if the battery is used for a long cranking period in trying to start the tractor, if it is left in the cold for a long time, or if a short circuit develops.

A discharged battery in good condition can be recharged. This is done by a commercial battery charging unit. Both terminals of the battery should be disconnected during recharging. The positive lead from the charger connects to the positive post of the battery and the negative lead to the negative post. Between 12 and 24 hours may be needed to recharge the battery. Follow the charger instructions carefully to prevent further damage to the battery and to prevent a possible explosion. Always remove the caps from the cells, except on maintenance-free batteries, so all gases formed can escape. Keep sparks and open flames away from the battery at all times. Do not allow a battery to become completely discharged in freezing weather or the battery may break open.

Starting Circuit

The starting circuit consists of the battery, the starter (or ignition) switch, the starter solenoid and the starter motor. Arrangement of these components is shown in Figure 6-3.

To start an internal combustion engine, an electric starting system engages the engine's flywheel and turns it until the engine starts. The solenoid opens and closes the circuit switch which transmits electric current from the battery to the motor. Electricity causes the smaller gear located on the motor shaft to turn and mesh with the teeth on the flywheel, which cranks the engine. With these parts working together, when the fuel ignites, the engine begins to run.

Figure 6-3
COMPONENTS OF AN ENGINE STARTING SYSTEM.

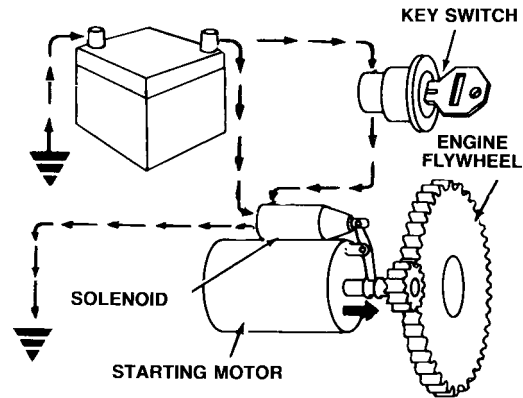

The Charging Circuit

The charging circuit restores the electrical energy lost from the battery during starting. During normal operation of the tractor, this circuit takes over from the battery to supply current for ignition, lights and most other accessories. If a large amount of current is needed to operate electrical devices, the battery will supply enough to make up the deficiency.

The charging circuit includes the battery, a voltage regulator and a generator or alternator (see Fig. 6-4). The latter two devices convert mechanical energy from the engine to electrical energy for the battery and other circuits.

Generators produce a type of pulsating direct current (DC) and alternators generate alternating current (AC). The AC is converted to DC for use in the charging circuit. Alternators deliver more electrical energy at low speeds than do generators. Alternators require less maintenance so they are almost always found on newer equipment. They are driven from the engine crankshaft by a V-belt which also may drive the cooling fan.

A meter or warning light on the tractor instrument panel indicates whether the alternator or generator is charging at the correct rate. If the light stays on or the meter shows discharging after the engine has run for a short time, shut off the engine and find out why no charging is taking place. A loose drive belt is the most common cause. The operator's manual will show how to adjust tension on the belt.

Figure 6-4
COMPONENTS OF AN ALTERNATING
CURRENT (AC) CHARGING CIRCUIT.

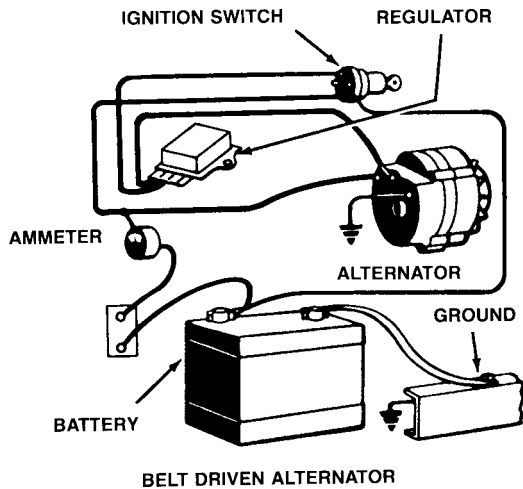

Alternators need no lubrication; older generators may need a few drops of light oil, according to instructions in the operator's manual. Their brushes also may need attention if the generator is not charging properly.

The voltage regulator in the charging circuit controls the amount of current flowing through the circuit and protects the battery from overcharging. No maintenance is required on the voltage regulator.

The Ignition Circuit

This circuit is found only in spark-ignition engines. It actually involves two circuits — the primary and secondary ignition circuits. The two circuits are shown in Figure 6-5.

The primary circuit is a low-voltage circuit operating through the battery, the ignition switch, primary windings of wire in the coil, and the condenser and breaker points in the distributor. The primary circuit acts to induce or create the high voltage of the secondary circuit (ignition coil); it is this high voltage which produces the spark to ignite the fuel mixture in the cylinder.

The breaker points open and close by riding on a cam, which has as many lobes as there are cylinders in the engine (see Fig. 6-6). The distributor cam is connected directly to the engine crankshaft. When the ignition switch is on but the engine is not running, the breaker points may be closed. This is why the battery may discharge if the switch is accidentally left on. The simple primary circuit is from the positive side of the battery, through the switch, through the primary coil winding, and through the points to ground and back to the negative side.

However, when the engine is turning over — even slowly — the distributor cam is rotating,

opening and closing the points. Each time the points open, the current flows into the condenser for a brief moment, then discharges back into the primary wiring.

The condenser acts as an electrical “shock absorber.” As the current flow is halted through the primary circuit, the magnetic field around the primary windings in the coil breaks down. Any time one magnetic field collapses near another, voltage is induced in the second field. In this case, the second field is in the secondary windings. There are many more wires in the secondary winding so the voltage produced there is much greater. The normal voltage in the primary circuit is 12 volts. In the secondary circuit it can be up to 25,000 volts.

This powerful surge is led into the top of the distributor. It then passes through the rotor which distributes the charge to the proper spark plug. At the spark plug, the high voltage enters the terminal at the top of the plug, flows down to the center electrode and jumps the gap to the side electrode grounded against the engine (see Fig. 6-7). The high voltage is needed so the spark will cross this space.

The spark jumping the gap between the electrodes ignites the air-fuel mixture in the top of the cylinder.

Figure 6-5
COMPONENTS OF PRIMARY AND
SECONDARY SPARK-IGNITION CIRCUITS.

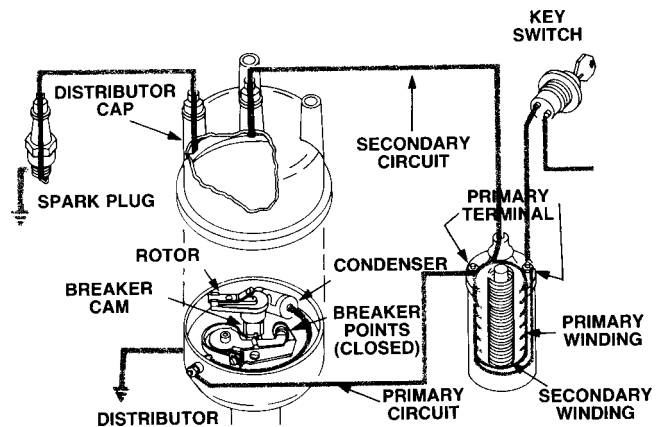

Servicing the Ignition System

Spark Plugs

Look in your operator's manual for instructions on checking and changing spark plugs. Use a spark plug socket wrench of the correct size to remove plugs for inspection. There is less danger that the wrench will slip and crack the porcelain insulator.

Have someone go over the plugs with you to determine whether they should be replaced or only

Figure 6-6
DISTRIBUTOR BREAKER POINTS OPENED BY
THE BREAKER CAM. (HOW MANY CYLINDERS
DOES THIS ENGINE HAVE?)

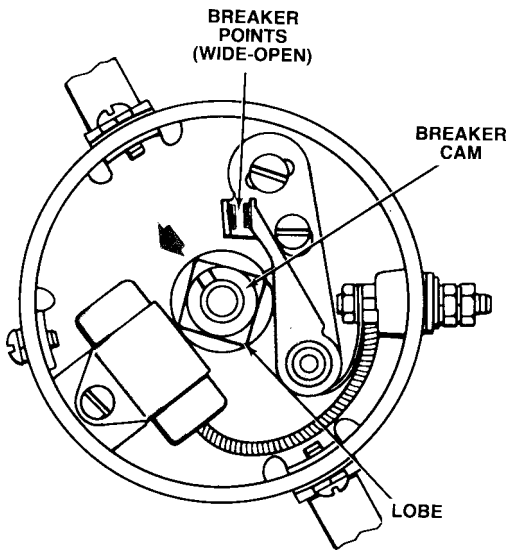
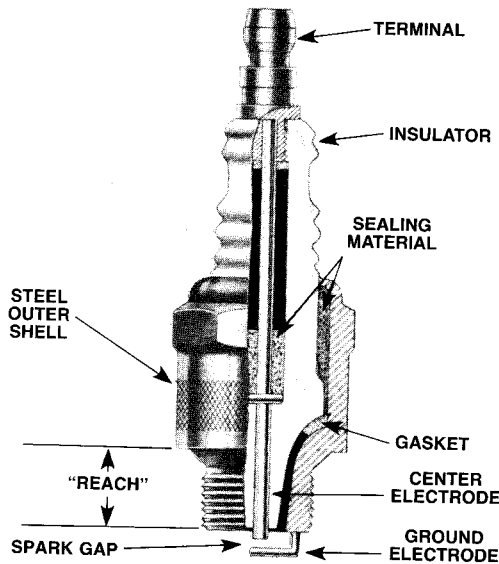

Figure 6-7
CUTAWAY VIEW OF A SPARK PLUG.



cleaned. Cleaning should be done in a sand-blasting machine. Wash or use compressed air to remove sand particles from within the plug after cleaning. Do not use a powered wire brush to clean plugs. If plugs are badly fouled, it is best to replace them.

The gap between the center and side electrodes must be set precisely, according to the manufacturer's recommendations. Setting the gap too narrow may cause poor idling. A gap that is too wide may cause missing under full load.

Always use a round feeler gauge to check the gap of a used plug (see Fig. 6-8). A round gauge

will fit the burned electrodes which are no longer flat. When adjusting the gap, bend the electrode attached to the shell or outside of the plug.

Some spark plugs have copper or steel gaskets which seal them to the engine head to make them gas tight. When replacing these plugs, it is important to use new gaskets. Always tighten the spark plug enough to crush the gasket somewhat. Be sure the threads are clean. Use a wire brush to clean the threads if necessary, but don't let any dirt get into the cavity around the electrodes and insulator. Tighten the cleaned plug snugly, until you feel it draw against the gasket. Then give it about another half turn. Some plugs do not use gaskets but are sealed with a tapered fit.

Figure 6-8
CHECKING THE SPARK PLUG GAP WITH A
WIRE GAUGE.

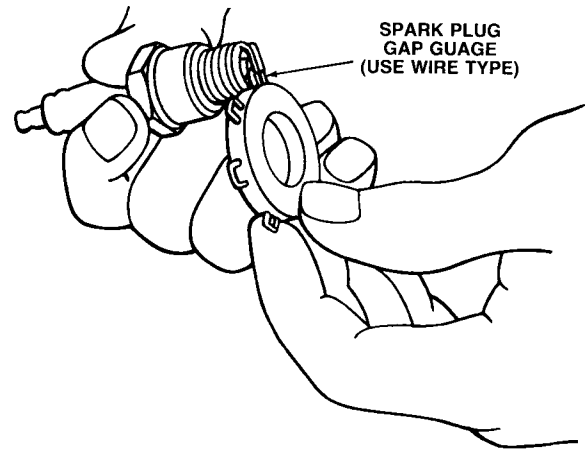

Keep Wires Clean

The wires leading from the distributor to the spark plugs carry high voltage. Therefore, they are heavily insulated. If the insulation cracks, the spark may arc across to the engine block and fail to reach the spark plug. Keep these wires wiped clean and keep dirt away from the spark plugs. Also wipe down the coil and distributor. Dirt around the high-voltage wires or spark plugs may collect moisture and "short out" the spark. Moisture on a dirty engine is a common cause of hard starting, especially in high humidity.

Checking Breaker Points

The breaker point gap should be checked periodically. Your operator's manual will tell you how often and will indicate proper spacing.

Use a flat feeler gauge to check the spacing. Be sure the engine has been turned until the points are wide open. The proper gap is provided when there is a slight drag on the feeler gauge as you pull it between the contact points.

If the points are set too close they will burn and pit rapidly. If the points are set too wide they may cause a weak spark at higher engine speeds. Be sure the breaker points fit together squarely. If they make only partial contact there will be burning, pitting and uneven wear.

When you finish working with the breaker points, run a strip of clean paper between the contact surfaces to remove any grease or dirt particles. Grease or dirt on the points will cause burning and pitting.

Learn By Doing

1. Recharge a battery. Obtain a discharged battery in otherwise good condition. Have an adult help

you hook the battery charger to the battery. (Be careful not to get the battery acid in your eyes or on your clothing.) Use a hydrometer to check the electrolyte before starting, then check it again periodically during charging.

Did all the cells recharge equally?

Do you think that after charging for a sufficient time the battery is usable? Why or why not?

How does a low-maintenance battery differ?

2. Clean a corroded battery and return to service.
3. Price several batteries at two or more stores. Why are they different prices? Which is the better buy?
4. Collect used parts and make a display of a starting circuit.

Checking up on the Electrical System

1. What is the difference between fouled and corroded spark plugs? Which is caused by too much heat? Too little heat? _____

2. What maintenance procedures are required on a liquid storage battery? A maintenance-free battery? _____

3. Draw lines representing battery cables to show how the circuits below are to be hooked up.

12-volt
system

12-volt
series
system

12-volt
parallel
system

12-volt
battery
charger

4. List the proper sequence of steps used to hook up cables between a booster battery and a dead battery during jump starting. Be sure to list the connection points for each step.

- A. _____
- B. _____
- C. _____
- D. _____

5. Name the three components of the charging circuit and their primary functions.

- A. _____
- B. _____
- C. _____

6. What kind of electrical system problem do you think a poor connection between the negative (-) post of the battery and the tractor engine or frame would cause? Which circuit(s) would be affected?

7. Match these words to the proper definitions:

- | | | |
|---------------|--------------------|--|
| A. Ammeter | E. Voltmeter | _____ describes the force behind the electron flow in a conductor. |
| B. Voltage | F. Resistance | _____ instrument used to determine if a battery is being charged or discharging. |
| C. Current | G. Electrolyte | _____ battery fluid mixture of sulfuric acid and water. |
| D. Hydrometer | H. Electric Energy | _____ describes opposition to electron flow in a conductor. |

8. The direction of current flow through a battery during charging and discharging is the same. T F
Why? _____

COOLING SYSTEM

What would happen if you left an empty pan on the stove with fire under it? It would get hot, eventually start smoking, and maybe even crack or burn a hole in the pan. However, if you discovered the pan getting hot and poured water into it, the water would pick up the heat thus cooling the pan. Tractor engines can be cooled in a similar manner. Internal combustion engines cooled by pumping water through them are “water-cooled” engines.

Another way to cool the heated pan would be to blow cool air over it. To do so requires a fan. Some tractor engines also are cooled with a fan. These are “air-cooled” engines.

The engine’s cooling system has two functions. It must keep the engine from overheating and it must maintain a uniform temperature in the engine. Up to one-third of the heat from the burning fuel released in an engine must be removed by the cooling system.

Engines can be damaged from overheating, but much damage also can be caused by operating them at temperatures too cool. Operating an engine too cool causes parts to wear rapidly and reduces power output. It also may cause spark plug fouling and a waste of fuel.

Tractor engines are built with large cooling capacities so, if properly maintained, the cooling system should help prolong the life of your tractor.

Water-Cooled Systems

Since few tractors have air-cooled engines we will devote most of this lesson to the water-cooled

systems. The water-cooled system consists of a radiator, fan, water pump, thermostat, hoses and water passages in the engine block.

Engine manufacturers recommend using a coolant mixture of clean, soft water and permanent antifreeze (ethylene glycol). This mixture contains the necessary rust inhibitors to protect the inside of the cooling system. This coolant mixture also has a higher boiling point than water, so the engine can be built to operate at a higher temperature.

The term “permanent” means the ethylene glycol can be used in the system all year. However, the coolant mixture still should be changed periodically, according to the instructions in your operator’s manual.

The correct ratio of ethylene glycol and water will depend upon how much winter protection you need for the engine. Freezing water can crack the engine block or cylinder head. Where little or no winter protection is needed the usual coolant ratio is half water and half ethylene glycol. More anti-freeze and less water protects against lower temperatures. Ethylene glycol should not be used alone in the cooling system; it must be mixed with water. Usually a mixture of 50% water and 50% antifreeze is adequate for most climates.

Coolant filters are found on all new engines. Change them as recommended.

The Radiator

In a water-cooled engine, water soon would boil away if the heat was not removed (see Fig. 7-1). To

Figure 7-1
A COOLING SYSTEM MUST REMOVE LARGE AMOUNTS OF HEAT.

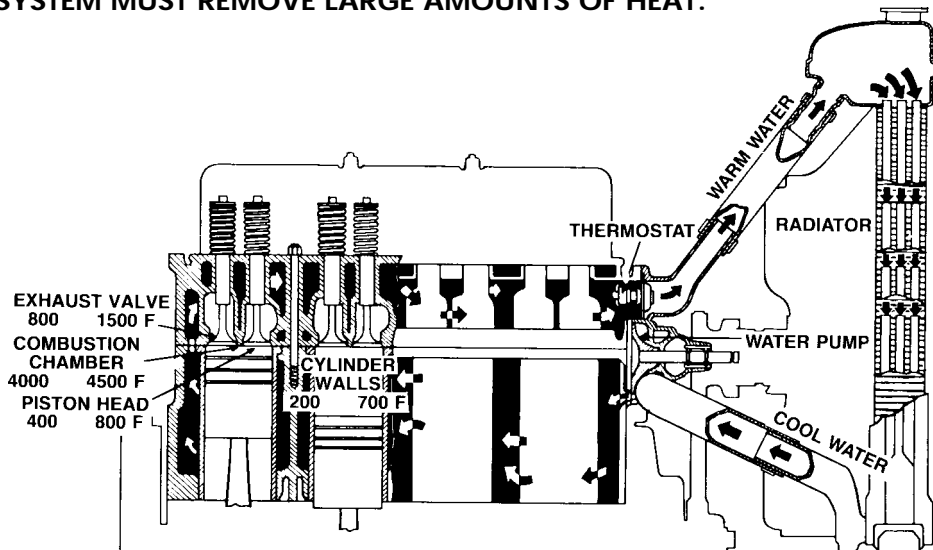

remove some of the heat, water is passed through a radiator. Air passes around the fins and tubes, picks up the excess heat and carries it away. A fan keeps a large amount of air moving through the radiator. So, in a water-cooled engine both water and air are used for cooling.

On some engines, oil from the transmission or hydraulic system is circulated through a coil in front of the radiator. This helps cool the oil.

Never add very hot or very cold water to the radiator. Inspect radiator hose connections often to make sure there are no leaks. A leaky radiator hose or leaky radiator causes you to keep adding coolant. Check the inside of hoses, too. Rubber wears off with age and small pieces can plug the radiator.

Pump and Thermostat

The water pump circulates the coolant through the cooling system (see Fig. 7-2). The pump draws hot coolant from the engine block and forces it through the radiator for cooling. If the pump fails to circulate the coolant, heat is not removed from the engine and overheating will occur.

The thermostat provides automatic control of engine temperature. This heat-controlled valve regulates the flow of water between the cylinder block and the radiator. During engine warm-up the thermostat remains closed, stopping water circulation until the engine warms up to operating temperature. Once the engine is warmed the thermostat opens and hot coolant flows from the engine to the radiator and back.

Figure 7-2
LIQUID COOLING SYSTEM ON A MODERN ENGINE.

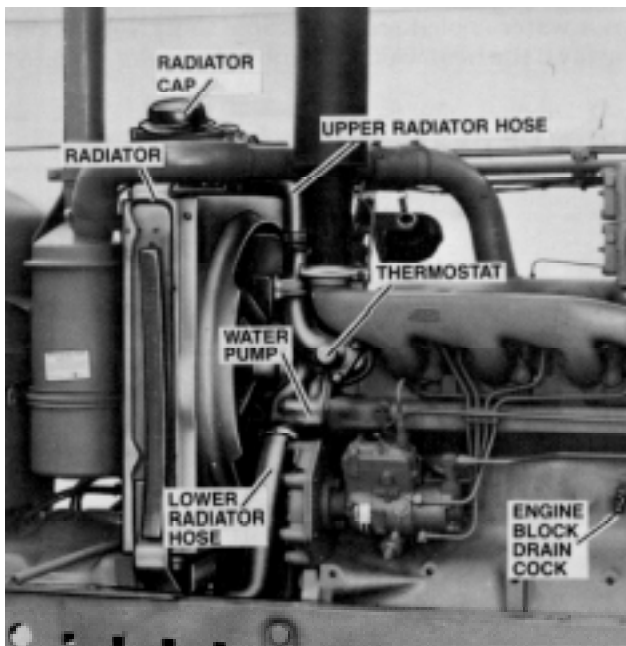

An engine operating at a temperature lower than recommended will use more fuel, have less power, and have increased cylinder wear. Be sure the thermostat on your cooling system works properly. And, never operate an engine without a thermostat.

Here's how to check a new thermostat or one that you have removed from your tractor (see Fig. 7-3).

Use a string to suspend the thermostat in a can of water. Place an oven thermometer in the water. Heat the can of water on a stove or hot plate. As the water heats up you can watch the thermostat to see if it opens at the correct temperature. If the thermostat is working properly it will open when the water reaches the same temperature indicated on the thermostat.

Figure 7-3
TESTING A THERMOSTAT.

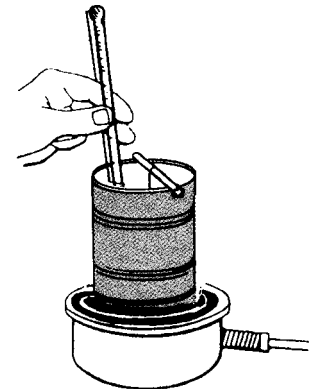

Pressure System

On most engines the radiator cap seals the radiator. It contains one valve that admits air to keep the radiator tubes from collapsing and another that lets liquid escape from the system when the internal pressure reaches a predetermined level (see Fig. 7-4). We call this a pressure cooling system.

If your engine has such a cooling system make sure that the gasket used to seal the radiator cap fits tightly and that it doesn't leak. Also, be sure the engine has cooled before you remove the radiator cap. If it must be opened, cover with rags and release the pressure slowly. If you remove the cap while the engine is hot and the system is still pressurized, you could be burned. Pressurized systems typically operate at temperatures of 200°F or higher.

It is important not to overfill the radiator of your engine. Some space must be left for coolant expansion. If there is too much liquid, the excess will drain off in the overflow pipe. Coolant running from the overflow pipe usually means the coolant level is too high, not that the engine is overheating. New tractors have containers attached to the radiator to catch and recirculate coolant forced out from overfilling.

Figure 7-4
THE RADIATOR CAP MAINTAINS A PRE-SET
PRESSURE WITHIN THE COOLING SYSTEM.

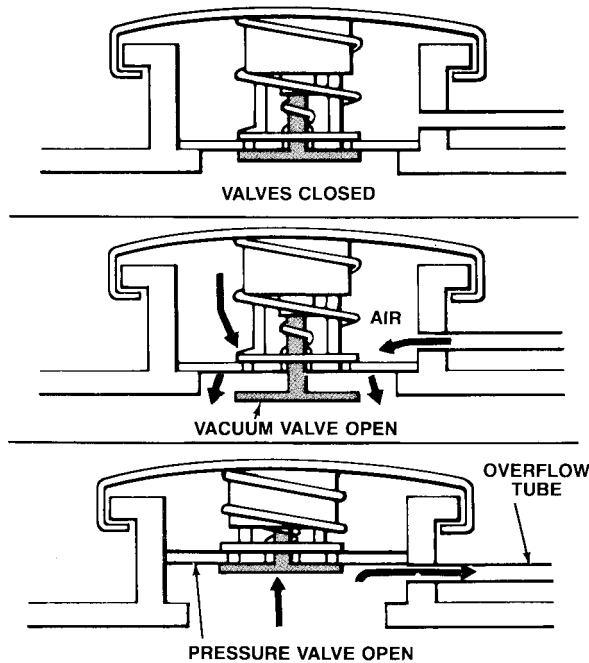
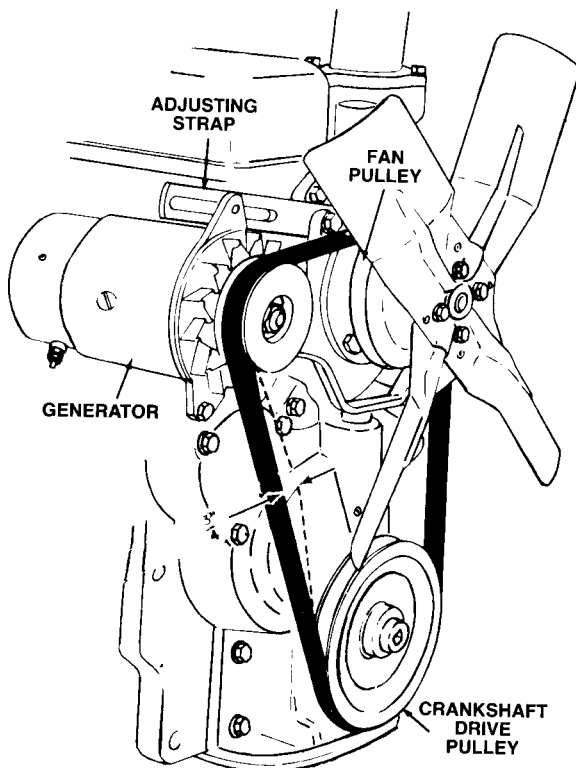

Figure 7-5
MAINTAIN PROPER TENSION ON THE
FANBELT.



Fans and Belts

Engines are equipped with a V-belt to drive the fan. It should be adjusted for the proper tension between the pulleys (see Fig 7-5). Correct tension is important so the fan, water pump and other accessories driven by the same belt operate as designed. Your operator's manual will tell you the proper tension.

Allow Engine to Cool Before Stopping

A gasoline engine may be so hot after pulling a hard load that it will keep on running after you turn off the switch. This happens when red-hot carbon in the combustion chamber ignites the fuel. The best way to prevent it is to allow the engine to idle for about five minutes at one-half to three-fourths throttle until it cools somewhat. Then, when you turn off the switch, the engine will stop. Turning off a hot engine without first allowing it to cool is a common cause of sticking valves.

Newer tractors may have gauges to tell you when the engine is cool enough to shut off.

Air-Cooled System

Air-cooled engines are used in small and large tractors. They also are used as power units on many machines.

Since air-cooled engines are often operated in dusty areas you must be especially careful to keep the air inlet screen clean. The engine must have sufficient air for cooling. On air-cooled engines you will find a metal shroud to direct the air flow. The metal keeps the air near the engine. Be sure dirt, leaves and trash do not collect in the shroud and between the fins around the cylinders. Restricted air flow may allow overheating and cause burned pistons or valves. Some engines have a section of the shroud which can be removed for cleaning but should be replaced before restarting the engine.

Learn by Doing

1. Change the coolant in a tractor following the operator's manual.
2. Change the filter on a tractor engine cooling system. Report or illustrate the results to your club.
3. Survey 3-4 farms in your community. Note the type of engine and cooling system for each tractor you find. Have the cooling systems been serviced regularly?
4. Price a water pump at an implement dealer. Were you surprised at the cost?

Checking up on the Cooling System

1. Briefly describe the two functions of a tractor's cooling system.

A. _____

B. _____

2. Why is a special coolant solution used in the water-cooled system? _____

3. What are three main causes of radiator leakage? _____

4. What two maintenance checks do you think should be made daily on a tractor's water-cooled system?

A. _____

B. _____

What should be checked daily on an air-cooled engine?

HYDRAULIC SYSTEM

You learned in your first year of the tractor project that hydraulic systems provide the “muscles” for controlling various tractor operations. This is possible because an efficient hydraulic system multiplies a small amount of applied force to do a great amount of work.

The brakes on a vehicle are a simple example of hydraulic power. Slight force on the brake pedal slows or stops the vehicle’s movement. Likewise, only a light touch of the hand on the tractor’s hydraulic control lever is needed to lift implements weighing several hundred or thousands of pounds.

The most common hydraulic functions found on modern tractors involve: steering, brakes, transmissions, implement control, remote cylinders and hydraulic motors (see Fig. 8-1). These functions may use a common hydraulic fluid supply or each may have its own reservoir where oil is stored.

The fluid in a hydraulic system serves not only as the power-transmitting medium but also as the system’s lubricant and coolant. You must, therefore, carefully follow your operator’s manual for selecting the recommended fluid and servicing any hydraulic system on the your tractor.

The Hydraulic Principle

Figure 8-2 illustrates the principle of hydraulic power in a simplified system. A scientific principle discovered by the French physicist Pascal governs what happens in the hydraulic system. Pascal’s Law states that “pressure applied to a fluid in a closed container is transmitted with equal intensity throughout the liquid and at right angles (perpendicular) to the surface of the container.” Any force applied to the drive piston is transmitted through the liquid to the driven piston. You can see in the bottom part of Fig. 8-2 that one piston is driving four others.

Other components are needed to build a practical system. A reservoir supplies the fluid needed (see Fig. 8-3). A pump moves the fluid from the reservoir through the system. A control valve regulates the direction of fluid flow, and some type of cylinder or hydraulic motor does the work (see Fig. 8-4.)

Figure 8-1
A MODERN TRACTOR WITH A COMPLETE HYDRAULIC SYSTEM.

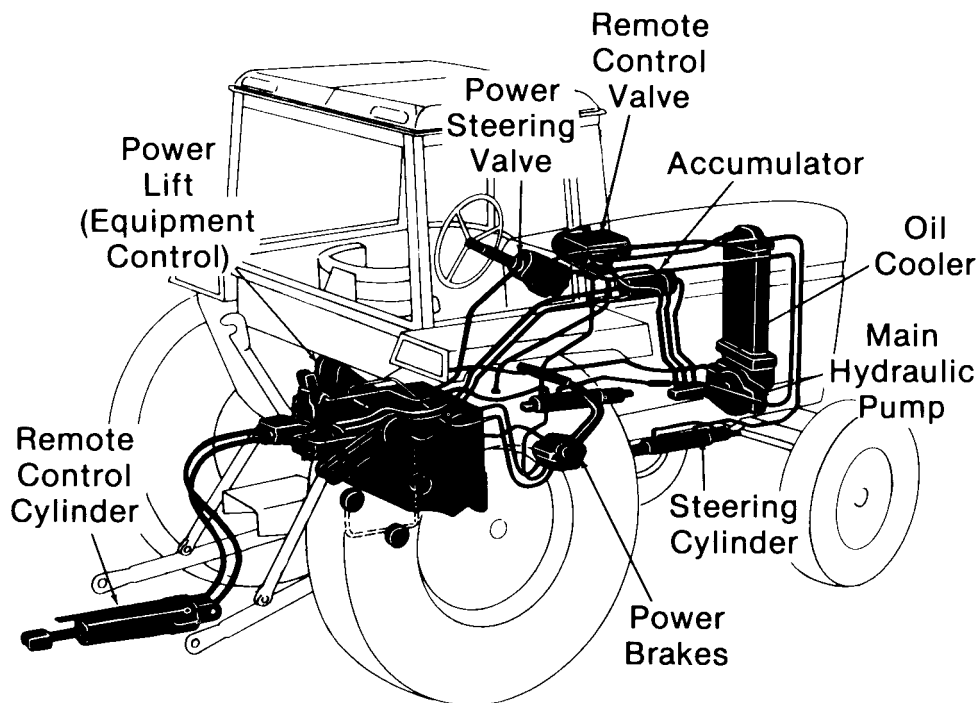

Figure 8-2
A HYDRAULIC SYSTEM MULTIPLIES FORCE MANY TIMES.

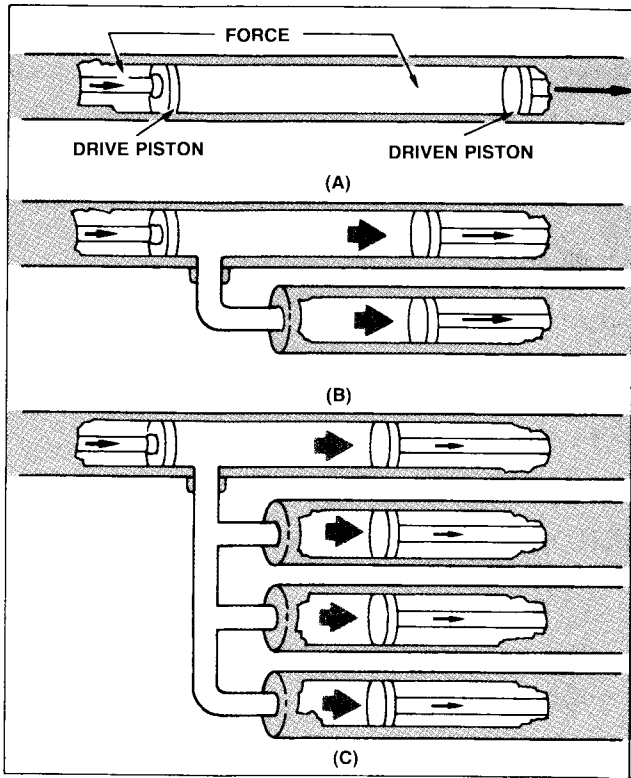
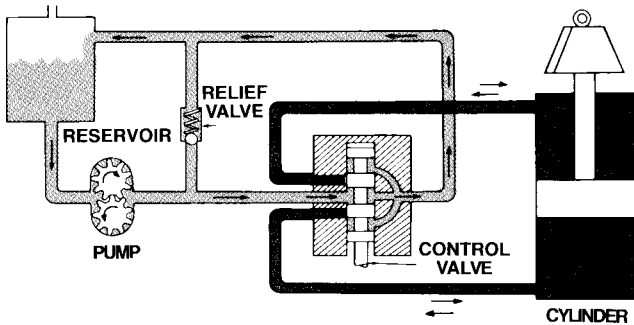

Figure 8-3
A SIMPLE HYDRAULIC SYSTEM.



Using the Hydraulic System

The tractor operator's manual should be studied carefully so that functions and operation of all segments of the hydraulic system are understood. Special attention should be directed to the hydraulic load-sensing controls, hydraulic differential locks, and controls for remote operations. Proper settings for load-sensing controls will depend upon the implements being used and the degree of sensitivity desired. Operation of differential locks will be discussed in Lesson 9.

Remote cylinders or motors are connected to the main hydraulic system, usually by special

flexible lines. Tractors may have only one or as many as three or four sets of ports for attaching these lines. It is important to know how the lines are to be connected. This information will be in the operator's manual.

Figure 8-4
BASIC OPERATION OF A HYDRAULIC MOTOR.

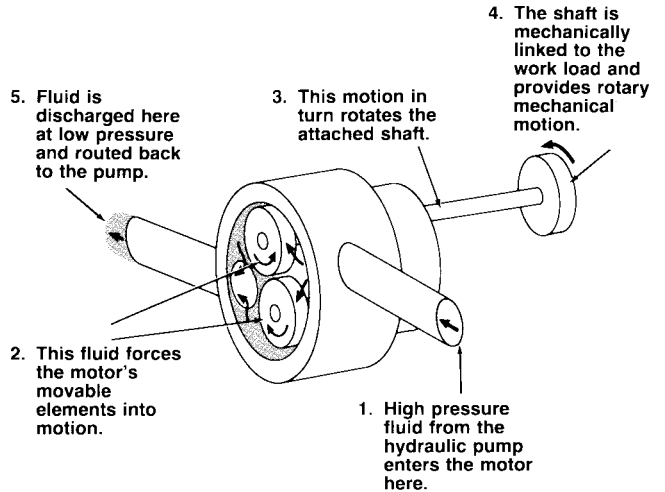

Hydraulic System Maintenance

A well-maintained hydraulic system seldom gives the operator any trouble. Check the oil level regularly. Changing the oil and filters regularly and keeping the fluid lines tight help prevent problems and are necessary maintenance on the hydraulic system.

Hydraulic fluid is a special petroleum oil refined to meet the demands of the system. It contains additives which help prevent rust, corrosion, oxidation and foaming, and which help withstand extreme pressures as well. However, oil in the hydraulic system can become contaminated just like engine and transmission oil. Dust, rust, moisture and metal particles will damage the hydraulic system. When checking fluid levels and changing filters be especially careful to clean the surface around the dipstick, filler cap and filter so dirt does not enter during checking or filling. Also, clean remote cylinder hose ends.

Follow the manufacturer's recommendations for the type of fluid to use in your tractor's hydraulic system. Proper selection of oil is mandatory for satisfactory performance and life of your hydraulic system. One survey indicates that about three out of every four problems in hydraulic systems are caused by using either the wrong or contaminated fluid. Manufacturers' warranties on the hydraulic system become voided if the wrong fluid is used

and the system fails. Fluid for hydraulic brake systems must not be used in the tractor's main hydraulic system. Brake fluid is not petroleum based and could ruin the system.

Do not look for leaks with your hand. Use a piece of cardboard or paper. Oil under pressure can penetrate the skin and cause serious injury.

Routine checks for oil leaks will prevent excessive loss of fluid and possible overheating. Air leaks will cause the oil to oxidize rapidly forming harmful gum and sludge.

Remember, hydraulic systems on newer tractors are an integral part of the entire tractor. When the hydraulic system fails the tractor is inoperable and expensive to repair.

CAREFUL CARL'S SAFETY RULES FOR HYDRAULICS

- Always lower implements before working on them.
- Park equipment where children cannot reach.

- Block up hydraulic implements if you must work on them in the raised position.
- Never service a hydraulic system while the engine is running, unless absolutely necessary, such as while bleeding the system or looking for leaks. Use a piece of cardboard to check for leaks.
- Do not remove cylinders until the implements are resting safely on the ground or blocked up safely. Make sure the engine is off and the key is removed.

Learn by Doing

1. Change the filter on a hydraulic system. How much did this cost (filter, oil, etc.)?
2. Clean the area of a tractor where hydraulic hoses are connected.
3. Obtain a used oil pump. Take it apart to learn how it works. Describe and illustrate at a club meeting.
4. Make a list of how hydraulics are used on a farm.

Checking Up on the Cooling System

1. Name the basic parts of a tractor hydraulic system. _____

2. List three maintenance problems commonly associated with hydraulic systems. _____

3. Give one safety rule which you should follow to avoid injury from the hydraulic system. _____

4. Explain the difference between a hydraulic pump and a hydraulic motor. _____

5. What is the most common cause of premature hose failure? _____

6. How do you relieve hydraulic pressure before servicing the tractor hydraulic system? _____

DRIVE TRAIN

The power that the engine develops can be transferred to implements either through the wheels, the PTO or hydraulic pressure. On newer tractors, all these systems are connected into a drive train which transmits power from the engine to the wheels.

Beginning at the engine and tracing the flow of power along the train are these components: the clutch, transmission, differential and, just before reaching the wheels, the final drives. These components are shown in relation to each other in Figure 9-1.

Figure 9-1
LOCATION OF COMPONENTS OF THE POWER TRAIN IN A TRACTOR.

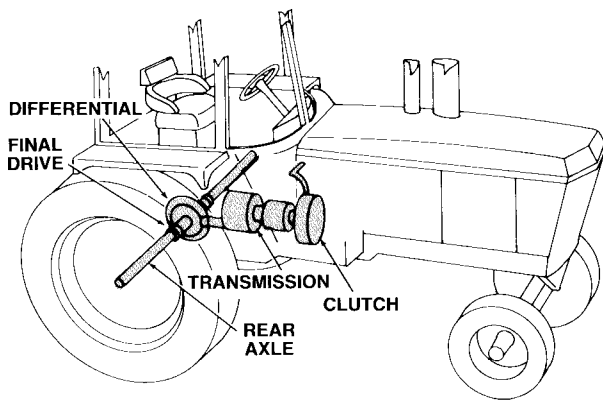

The Clutch

The clutch links the engine to the transmission. Power is transmitted from the clutch to the transmission. If the engine were coupled directly to the transmission, power would be transmitted continuously, as long as the engine is operating. The clutch enables power transmission to occur smoothly when starting out, to be interrupted momentarily to shift between speeds, and to be halted for stopping tractor movement.

Clutches may be either mechanically or hydraulically actuated. Clutches on older tractors and smaller models are mechanical. Those on newer tractors, especially larger models, are hydraulically operated. Some newer tractors which use torque converters in fluid drives do not have clutches.

The Mechanical Clutch

A good way to demonstrate how a disk clutch works is: Place a half-dollar between two quarters and pinch the quarters tightly with your thumb

and forefinger. Have someone try to turn the half-dollar. What happens? Then loosen your grip slightly. What happens? The person can turn the half-dollar easily.

Figure 9-2 shows the parts of a simple, single-disk clutch and what happens when the clutch is engaged and disengaged. While the clutch pedal is out, strong springs force the pressure plate and clutch disk against the spinning flywheel. Torque from the flywheel is transmitted through the clutch and into the transmission. When the pedal is depressed, a throw-out bearing pulls the clutch plate back from the clutch disk breaking power transmission.

Figure 9-2
PARTS OF A SIMPLE DISK CLUTCH.

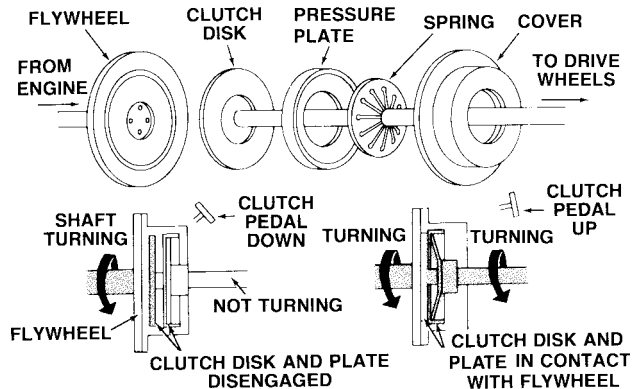

The multiple-disk clutch works in much the same way as the single-disk, except that several disks are used to obtain more frictional area in the multiple-disk type.

Disk clutches may be either of the “dry” or “wet” type. Dry means that the clutch operates and is cooled by air. Wet means that the clutch operates and is cooled in oil. On the wet-type, the oil level must be checked and the oil and filter changed regularly.

Dry types may occasionally require greasing at the bearings but be careful! Too much grease can get into disk faces and cause poor operation, including slipping, grabbing and dragging. Follow the instructions in your operator’s manual for servicing each.

Caution: Do not “ride” the clutch; that is, leave your foot on the pedal while it is engaged. This causes clutch slippage, overheating and excessive wear.

Transmissions

The turning force developed at the crankshaft of the engine is called torque. Torque and speed together give power. When more torque is needed for pulling heavy loads, reduce speed. Reducing the speed increases the tractor's pulling ability with the same power. Likewise, increasing the speed reduces torque.

Gear Transmissions

Gears are used to change speed in a tractor and are the basic components in the power train. They transfer power from one shaft to another. Basically, the gears apply the twisting force (torque) to the rotating parts. Torque varies with relative gear size and a small gear driving a larger gear gives less speed and more torque and vice versa (see Fig. 9-3 and 9-4).

Figure 9-3
TORQUE VARIES WITH RELATIVE GEAR SIZE.

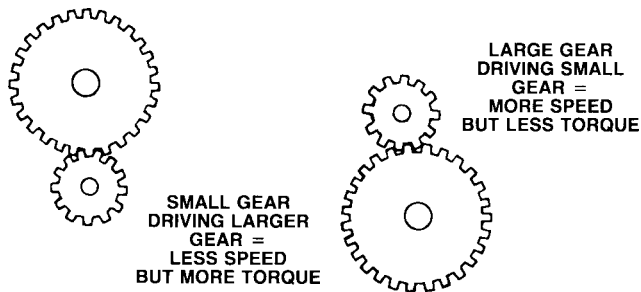
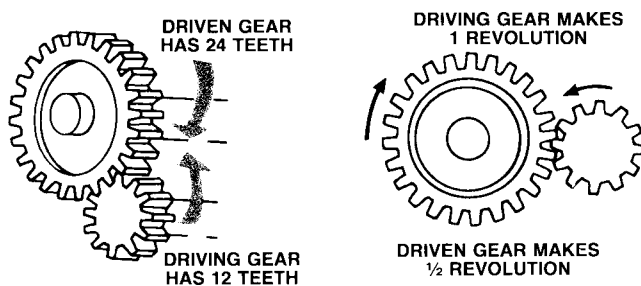

Figure 9-4
OUTPUT SPEED DEPENDS ON RELATIVE GEAR SIZE; SMALL GEAR ALWAYS TURNS FASTER.



Gears are usually classified by type of teeth. Meshing gears, as illustrated, must have teeth of the same size and design and at least one pair of teeth in contact at all times.

There are several types of gear teeth and arrangements. Three major types are straight cut, helical cut and planetary. Figure 9-5 illustrates these.

Straight-cut teeth gears enable speeds to be changed directly by sliding the gears together along a shaft. Helical spur gears are very common

in transmissions because they are quieter at high speeds and are more durable. Planetary gear sets also are popular because each set can have more than one speed change and the work load can be spread over several gears, reducing wear and tear on any one gear.

Figure 9-5
THREE TYPES OF GEARS COMMONLY FOUND IN TRACTOR TRANSMISSIONS.

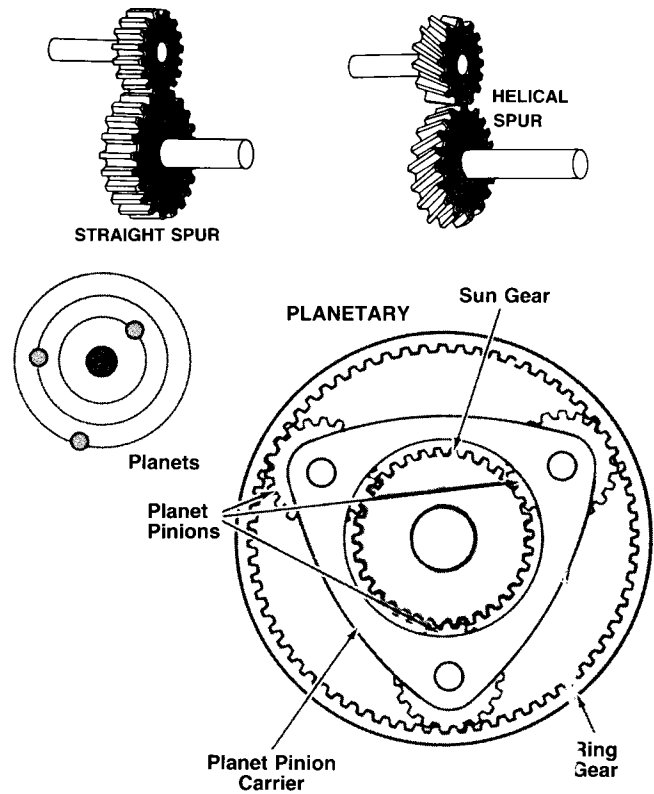

Mechanical Transmissions

Gear shifting in a mechanical transmission is done with the clutch and shifting lever. After disengaging the clutch, the operator uses the lever to reposition gears in the transmission. Gear repositioning may be accomplished by sliding gears along shafts or by locking freely rotating gears to driving shafts by means of shifting collars. If synchronizers are added to the transmission, the operator can shift between certain gears without stopping the tractor. A synchronizer matches the speeds of two gears so they engage or mesh smoothly.

Hydraulic-Assist Transmissions

Hydraulic assisted transmissions are common on modern tractors. They provide the advantage of being able to shift them while "on-the-go" and the flow of power is not interrupted. Shifting is accomplished by routing fluid to hydraulic clutches inside the transmission. The operator doesn't actually

select gears but instead selects clutches to engage certain gears which are in constant mesh.

Hydrostatic Transmissions

Hydrostatic transmissions use a fluid at high pressure but relatively low speed to transmit power. A pump connected to the engine pumps hydraulic fluid through a number of circuits in a closed system to a motor. The power output from the hydraulic motor is directed to the drive wheels. Because the rate, direction and pressure of oil in the system is easily controlled, many combinations of speed and torque are available. However, hydrostatic transmissions are not very energy efficient.

Hydrodynamic Transmissions

This fluid-type system uses fluids at high speeds but relatively low pressure; another name for this drive is a torque converter. It offers smooth shifting between an endless number of speeds and is usually coupled with a gear train to allow more efficient operation.

The torque converter functions by pumping hydraulic oil at high pressure against blades of a turbine causing it to spin. The speed of the oil can be varied to change the torque obtained from the turbine. The converter automatically increases or decreases torque so only a few gear ratios are needed.

Differentials

Power from the transmission goes to the differential. A differential takes power “around the corner” from the drive shaft to the drive wheels. It also makes one wheel speed up as the other slows down in turning. If you make a short turn by stopping the inside wheel, the outside wheel will go twice as fast.

You may compare the action of the differential to marching soldiers. When soldiers make a turn, the one on the inside slows or stops and waits for those on the outside to come around. In a differential, there is a small gear on the end of each axle (see Fig. 9-6). Each axle turns a wheel. Two or three small bevel pinion gears connect to these two gears. The bevel pinion gears are attached to a case which is bolted to a larger gear called the ring gear. When the tractor is traveling straight ahead, the gears on the ends of the axles turn with the ring gear. The bevel pinion gears do not turn. They are carried around by the carrier.

Now, if the tractor is turned, one wheel slows down and the small bevel pinion gears turn, thus making the outside wheel speed up. The outside wheel speeds up at the same rate the inner one slows down. If you should turn a sharp corner and stop the inside wheel, the bevel pinion gears cause

the outside wheel to turn at twice the speed required for moving in a straight line.

Differential Locks

A differential lock is used when power must be delivered equally to both wheels. If a tractor loses traction on one wheel, which begins to spin because of differential action, locking out that action will help regain traction.

Figure 9-6
THE TRACTOR DIFFERENTIAL.

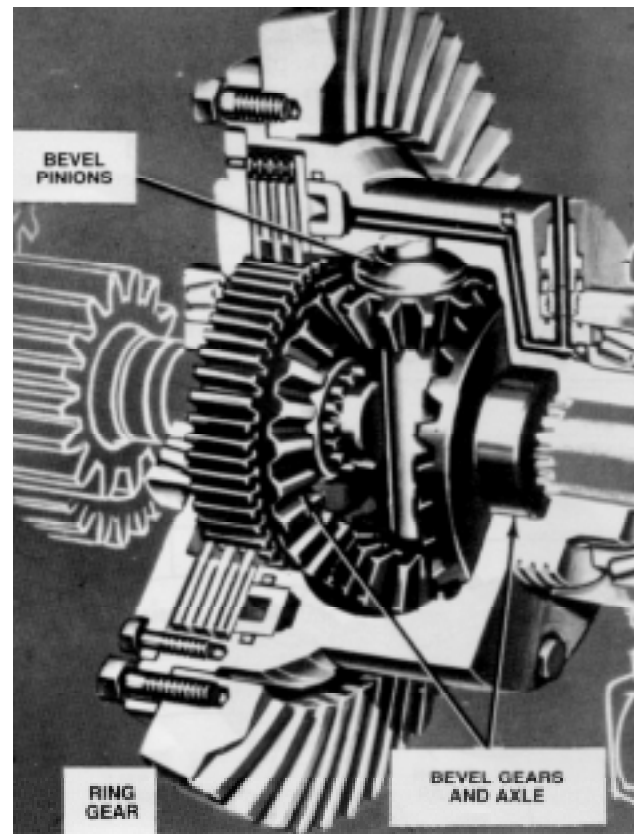

Differential locks may be either mechanical or hydraulic. Both types may be engaged while the tractor is in motion. Differential locks should never be left engaged when the tractor is turning because they force both wheels to turn at the same speed.

Final Drives

The final drive is the last link carrying the power of the engine to the wheels. Its primary functions include providing the final gear reduction for slowing down the tractor and increasing torque at the drive wheels. The most common types of final drives on tractors are the pinion drive and the planetary drive.

Pinion final drives consisting of a pinion gear and a spur gear are sometimes mounted within the differential case (see Fig. 9-7). In this older design, all final gearing is kept within one case for a more compact unit with a single lubrication system. This design allows a straight axle shaft to be used, providing space for wheel tread adjustment. Pinion drives may be located at the outer ends of the final drive shafts.

Figure 9-7
A PINION GEAR ASSEMBLY FOR SPEED REDUCTION LOCATED IN THE DIFFERENTIAL.

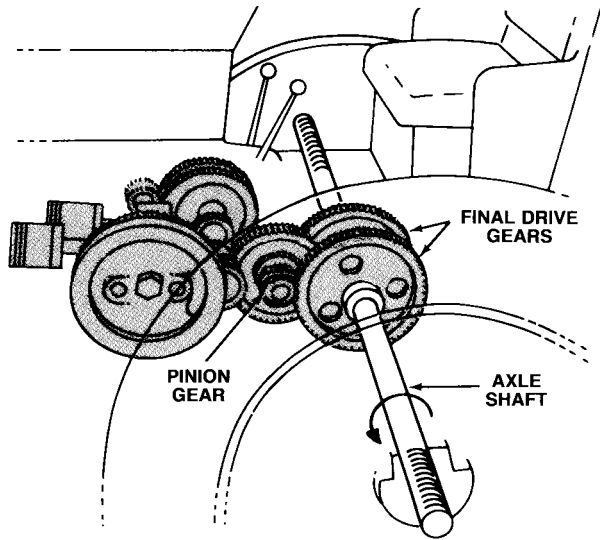

Planetary drive sets are smaller and more compact than pinion type. They also are sturdier because stresses are distributed over several gears. Like pinion drives, they also may be placed next to the differential or at the outer ends of the final drive shaft (see Fig. 9-8).

Maintenance

Because of the many possible types of designs in power transmission systems, it is impossible to give specific instructions for maintenance. Therefore, it is very important that you follow your operator's manual.

All components are essentially sealed units built of strong steel. Gears are assembled on shafts

which turn on large ball or roller bearings. Good lubrication is critical to the proper functioning and long wear of these parts. Be sure to keep enough of the recommended lubricant in the transmission and gear cases. Also, be sure oils are kept clean by adding them regularly and changing oil and filters as recommended.

Repairs to drive train components can be very costly. So it's worth your time and effort to perform the specified maintenance in order to prevent costly and time-consuming repairs.

Figure 9-8
A TRACTOR FINAL DRIVE WITH PLANETARY GEAR ASSEMBLIES AT OUTER ENDS OF FINAL DRIVE SHAFTS.

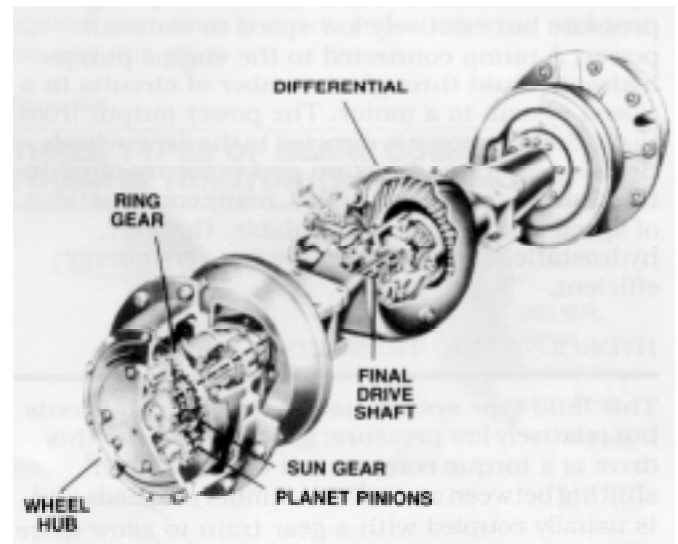

Learn by Doing

1. Check the fluid level of a tractor's transmission. Add oil if necessary.
2. Review the cost of overhauling the transmission on a tractor.
3. Review the specifications of a sample transmission oil.
4. Review how a differential works and why some machines have differential locks.

Checking up on Drive Trains

1. Name four functions of power trains. _____

2. Name three basic parts of a power train. _____

3. A small gear driving a larger gear will deliver (more/less) torque to the driven shaft? _____

4. Define "Torque." _____

5. What is the purpose of the clutch in the drive train? _____

6. Name and describe two types of gear transmissions. _____

7. What two jobs does the differential perform? _____

8. Can the differential lock be engaged while the machine is moving? Yes / No

9. List two advantages of planetary gears compared to pinion-type drives. _____

10. List three common causes of final drive failures. _____

THANKS FOR JOINING US!

This concludes Unit 2 in the 4-H tractor project series. You should have learned many new things about tractor operation, care and maintenance, especially about tractor systems, fuels and lubricants, servicing the tractor, and the importance of keeping operating cost records.

Of course, safety is always a concern when working with machinery. So, remember to follow the rules and safety practices provided by Carla and me and our farm friends.

To reinforce learning-by-doing, don't forget to complete the activities and quizzes supplied in each section of this manual. They will help expand your knowledge of the tractor and give you a chance to gain practical experience in everyday operations. If you forgot to do the activities as you went along, now's the time to catch up. Once you're done, you'll be ready to move on to Unit 3.

GLOSSARY

ACCUMULATOR A container in a hydraulic system which stores energy as fluid pressure for use as needed to maintain system pressure. It may also act as a shock absorber to protect the system.

ALTERNATING CURRENT (AC) The flow of current which reverses its direction of flow at regular intervals, from positive to negative and vice versa.

ALTERNATOR A device which converts mechanical energy into electrical energy, producing alternating current. The AC is then changed to direct current (DC) by diodes in the alternator.

BATTERY (STORAGE) A device which produces electricity through chemical reactions and which can be recharged by reversing those same reactions.

BLEEDING Removal of unwanted air in a fuel or hydraulic system.

BREAKER POINTS Electrical contacts in an ignition distributor which control the flow of current into the ignition coil.

CETANE NUMBER The measure of a diesel fuel's ability to self-ignite when heated by compression. The higher the cetane number, the faster self-ignition occurs.

CHOKE A device to temporarily enrich a fuel/air mixture by increasing the amount of fuel in it. The choke is used to help an engine run smoothly until it reaches its normal operating conditions.

CLUTCH A device which connects or disconnects engine power output from a transmission or drive shaft.

CONDENSER A component in the primary ignition system which protects breaker points from burning as they open and close.

CURRENT The flow of electrodes through a conductor. Current is denoted by the term "ampere" and is the component of electricity which produces work.

DIRECT CURRENT (DC) The flow of electrical current in one direction only, from the positive to the negative side of a circuit.

DISTRIBUTOR A switch-like device in a spark-ignition engine which directs electrical current to one spark plug at a time.

ELECTROLYTE A solution capable of conducting an electric current. The sulfuric acid and water in a storage battery is an electrolyte.

GENERATOR A device for converting mechanical energy into electrical energy. The energy produced is smoothed out to direct current for use in the circuits of the tractor.

HYDRAULIC MOTOR A motor whose motion and power are produced by fluid flowing through gears or vanes.

HYDRAULIC PRESSURE A force produced by flowing liquid.

HYDROMETER An instrument for measuring the specific gravity of a liquid.

IGNITION COIL A type of electrical transformer which increases the normal voltage of an ignition system to a very high voltage for igniting the fuel mixture.

OCTANE NUMBER The measure of the anti-knock quality (resistance to pre-ignition or uneven ignition) of a fuel.

PINION (GEAR) The smaller of two gears meshing together.

PLANETARY (GEARS) A set of gears with one gear in the center (sun gear) surrounded by pinions (planet pinions) and all encased within a ring gear. Each pinion rotates on its axis while all rotate around the sun gear. Each pinion meshes with the inside of the ring gear.

RADIATOR A part of the liquid cooling system through which hot water passes for cooling.

REMOTE CYLINDER A hydraulic cylinder located away from the source of hydraulic power. It is usually connected to the system with flexible lines.

RESISTANCE Restriction of the flow of electrical current through a conductor. Resistance is produced by wires, light bulbs or other devices through which current must travel.

SERVICE CLASSIFICATION Two-letter codes developed by the American Petroleum Institute (API) to define the "quality" of engine lubricating oil. They enable oils from different manufacturers to be classified by their engine protection qualities.

SOLENOID An electromagnetic device which converts electrical energy to linear motion.

SPARK PLUG The electrical device which produces the ignition spark in the cylinder of a spark-ignition engine. It ignites the fuel-air mixture.

SPECIFIC GRAVITY (SG) The ratio of the density of a liquid to the density of pure water. If water has the arbitrary SG of 1.0, a liquid with the SG of 2.5 is two and one-half times as dense.

STARTER A part of the electrical system. A motor attached by gears to the engine's flywheel. The motor converts electrical energy to mechanical energy for cranking the engine.

SYNTHETIC LUBRICANT Petroleum-based lubricants which have been synthesized or built up to meet one or more special lubrication needs. Ordinary lubricants are produced mainly through refining processes which break down crude petroleum. Synthetics are created by building up products from basic constituents.

THERMOSTAT A heat-controlled valve used in the cooling system of an engine to regulate the flow of water between the cylinder block and the radiator.

TRANSMISSION A group of gears or other components which provide a selection of speeds for increasing or decreasing the output speed from an engine.

VISCOSITY RATING A numerical rating developed by the Society of Automotive Engineers (SAE). Defines the flow rate of lubricating oils.

VOLTAGE The force or pressure which moves electrical current through a conductor.