

# Modifying a Bale Unroller for Mulching between Plastic-covered Beds

John Wilhoit, Biosystems and Agricultural Engineering

## Introduction

The use of plastic mulches with drip irrigation has been shown to significantly increase yields for many warm-season vegetables. Plastic mulch systems offer many benefits, including moisture conservation, alteration of the soil temperature, and near complete in-row weed control. However, weed control between the rows of plastic can be a significant challenge. Weeds can hinder access for crop maintenance and harvesting activities, and the crop growth can be adversely affected from shading if the weeds get large enough. Weed control is especially challenging for organic vegetable growers because the use of herbicides is prohibited in organic production. One method of non-chemical control is to mulch heavily between rows. Hay and straw make good mulches for suppressing weed growth in vegetable production, but it is labor intensive to break apart and spread square bales. Using round bales for mulching can reduce the labor requirements since more hay is in each bale than in small square bales, they can be handled mechanically, and the round bales can be unrolled to peel off layers that are just about the right thickness for mulching between rows of plastic. But it is still labor intensive to roll round bales out manually.

Tractor three-point hitch-mounted bale unrollers that are conventionally used for feeding livestock are commercially available. Most have hydraulically-actuated arms to clamp the center axis of round bales and unroll them in layers by driving forward with the bale against the ground. These implements carry the bale along the centerline of the tractor. They cannot be used to unroll bales between rows of plastic, because there is not enough space to drive the tractor

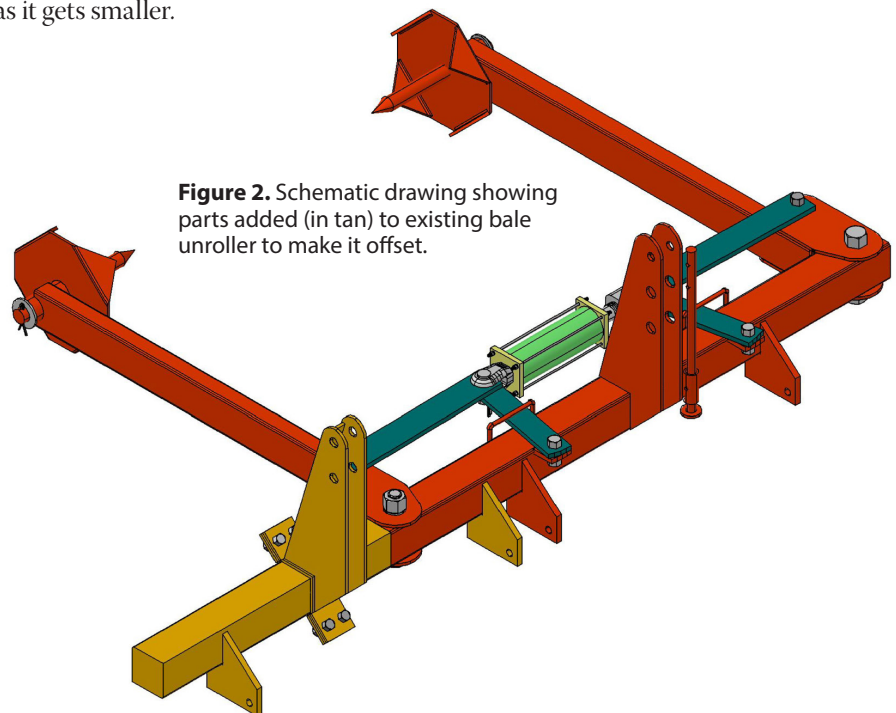

**Figure 1.** Offset bale unroller unrolling a round bale of straw between rows of plastic.

between the rows. A commercially available bale unroller was modified to offset the bale a sufficient distance so the bale can be unrolled in the space between rows of plastic while the tractor drives over the planted row (Figure 1). This was done by extending the toolbar and adding another mast and lower hitch point. We also added a hydraulic top link so the arms gripping the bale could be rotated downward to keep the bale on the ground as it gets smaller.

## Bale Unroller Modifications

The simple modifications to the bale unroller can be readily adapted to most conventional bale unrollers provided that the clamping arms are open at the end where they pivot on the toolbar, allowing the additional length of toolbar to be welded on (Figure 2). A Worksaver® brand bale unroller was chosen for this reason. The offset bale unroller is in-



**Figure 2.** Schematic drawing showing parts added (in tan) to existing bale unroller to make it offset.

tended for use with smaller round bales (4-foot width). They are the appropriate width for mulching between plastic rows on typical bed spacing, and they are considerably lighter than the larger 5-foot bales, so they can be carried by smaller tractors (around 35 hp minimum). The toolbar was extended 27 inches, and the new mast and lower hitch points were attached to the toolbar so that the bale was offset approximately 36 inches from center of the tractor (Figure 3). The schematic drawing in Figure 2 shows the original bale unroller components in orange with the parts added to offset the bale shown in tan. The added mast and lower hitch point were configured so the offset bale unroller can be used with either Category I or II three-point hitch systems. In our design, the new mast bolts on while the lower hitch points are welded on. The lower hitch points could be attached with bolts as well for added flexibility in three-point hitch setup and offset distance. The modifications leave the original mast and lower hitch points in place so the bale unroller can be attached for centerline bale unrolling, as originally designed. Note, however, that care should be exercised if the implement is used in this way because the toolbar extension will be protruding past the right side of the tractor. Design details for the offset bale unroller are available online

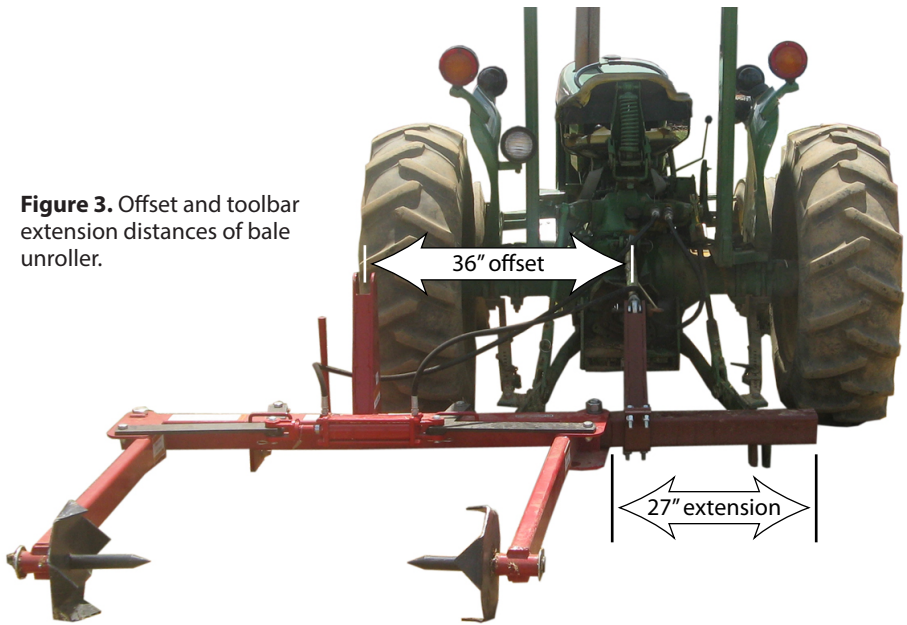

**Figure 3.** Offset and toolbar extension distances of bale unroller.

at the Biosystems and Agricultural Engineering Department Web site at [http://www.bae.uky.edu/ext/Specialty\\_Crops/plans.htm](http://www.bae.uky.edu/ext/Specialty_Crops/plans.htm).

### Hydraulic Top Link

The hydraulic top link used with the offset bale unroller is shown in Figure 4. By increasing in length to pivot the clamping arms downward, the hydraulic top link allows the offset bale unroller to be used for rolling bales out to a much smaller diameter than can be achieved with a fixed-length top link (Figure 5).

Keeping the bale on the ground at this small of a diameter with a fixed-length top link results in the tool bar being so low that it will cause damage to the plants or the plastic covering the bed (Figure 6).

With the addition of the hydraulic top link, the offset bale unroller uses two hydraulic cylinders (the other one is for the clamping arms), so the tractor used to operate it must have two double-acting remote hydraulic outlets. To use the offset bale unroller with tractors that only have a single remote available, a double hydraulic control valve can be added to



**Figure 4.** Hydraulic top link used with the offset bale unroller.



**Figure 5.** Round bale rolled out to small diameter with the offset bale unroller.



**Figure 6.** Damage to plastic mulch caused by the toolbar when using a fixed-length top link.

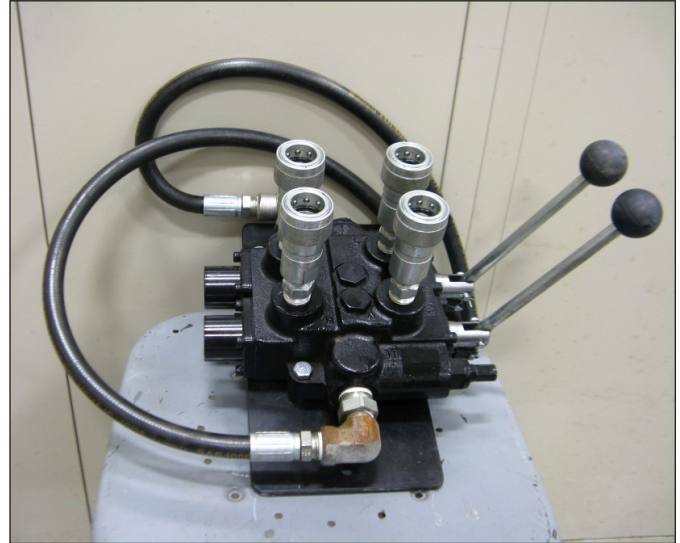

**Figure 7.** Double hydraulic control valve used to operate the offset bale unroller with tractors having a single remote hydraulic outlet.

the implement to allow control of both functions from a single outlet. The valve shown in Figure 7 is a four-way, three-position, tandem center directional control valve with two spools for operating two cylinders that was purchased from Bailey.net.com for this purpose. It was used in 2012 to operate the offset bale unroller with several different tractors that had only a single remote hydraulic outlet. The valve was positioned or clamped to the tractor in the vicinity of the tractor operator station in such a way that the tractor driver could access the levers to operate the unroller.

The hydraulic top link and the remote double control valves (if needed) and associated hydraulic hoses add about \$500-\$600 to the cost of the offset bale unroller. An offset bale unroller using a fixed top link length could be made for much less, but it could only be used to roll out a bale to approximately half its size because of the risk to planted crops and the plastic mulch from lowering the toolbar too much. Using the unroller without the hydraulic top link would certainly decrease the efficiency of the operations, but it could be a viable lower-cost alternative, as half-sized bales will be considerably easier to roll by hand than full bales.

## Summary

Round bales of hay or straw can be used to mulch between rows of plastic film mulch used in vegetable production. This practice may be particularly useful for organic production where herbicide use is prohibited. To make the job of unrolling round bales between rows of plastic easier, a commercially available three-point hitch mounted bale unroller was modified by extending the toolbar and adding a second mast so that the bale is offset, allowing the tractor to straddle a row of plastic while unrolling the bale between the rows. A hydraulic top link used with the offset bale unroller allows it to unroll the bales to a small diameter without damaging plants or the plastic film mulch covering the row. This new implement can help make bale unrolling operations much more efficient. For more information about the practice of using round bales for mulching between rows of plastic in vegetable production, see University of Kentucky Cooperative Extension Service publication ID-214: *Mulching with Large Round Bales between Plastic-covered Beds*.

Graphics provided by David Ash, Biosystems and Agricultural Engineering Department, University of Kentucky.

Mention or display of a trademark, proprietary product, or firm in text or figures does not constitute an endorsement and does not imply approval to the exclusion of other suitable products or firms.

## References

- Lamont, W.J. 2005. Plastics: Modifying the microclimate for the production of vegetable crops. *HortTechnology*. 15:477-481.
- Law, D. M., A. B. Rowell, J. C. Snyder, and M. A. Williams. 2006. Weed Control Efficacy of Organic Mulches in Two Organically Managed Bell Pepper Production Systems. *HortTechnology*. Vol. 16(2):225-232.
- Wilhoit, J. T. Coolong and T. Stombaugh. 2013. Mulching with Large Round Bales between Plastic-covered Beds. ID-214. University of Kentucky Cooperative Extension Service.

## Cooperative Extension Service

Agriculture and Natural Resources  
Family and Consumer Sciences  
4-H Youth Development  
Community and Economic Development

## MARTIN-GATTON COLLEGE OF AGRICULTURE, FOOD AND ENVIRONMENT

Educational programs of Kentucky Cooperative Extension serve all people regardless of economic or social status and will not discriminate on the basis of race, color, ethnic origin, national origin, creed, religion, political belief, sex, sexual orientation, gender identity, gender expression, pregnancy, marital status, genetic information, age, veteran status, physical or mental disability or reprisal or retaliation for prior civil rights activity. Reasonable accommodation of disability may be available with prior notice. Program information may be made available in languages other than English. University of Kentucky, Kentucky State University, U.S. Department of Agriculture, and Kentucky Counties, Cooperating.

Lexington, KY 40506 Revised 04-2024



Disabilities accommodated with prior notification.